

JK-8740

产品使用说明书&产品零件图册

Manual book & parts book

JACK 杰克

CONTENTS

目录

1	Installation	安装
1.1	Table dimensions	台板尺寸
1.2	Adjusting presser foot lift	调整抬压脚
1.3	Other Parts	其他部分
2	Sewing speed and rotating direction	电机转速和方向
3	Lubrication	润滑
3.1	Lubricating oil	润滑油
3.2	Lubricating	润滑系统
3.3	Priming oil	启动注油
3.4	Priming	补充油
3.5	Changing oil	更换油
4	Proper operation	说用说明
4.1	Needle system	车针系列
4.2	Installing needle	针的安装
4.3	Threading	线
4.4	Thread tension	线松紧
4.5	Pressure of presser foot	调整压脚张力
4.6	Up-and-down position of presser foot	调整压脚高低
4.7	Adjusting differential feed dog	差动调节
4.8	Adjusting stitch length	调整针距
4.9	Adjusting lapped width of upper fabric	调整切布刀
4.10	Sp device	过线油组
4.11	Use of lap former	导布器
5	Adjustments	调节装置
5.1	Needle thread tension	针线松紧
5.2	Looper thread tension	弯针线
5.3	Top cover thread tension	喂针线
5.4	Height of needle	机针高度
5.5	Top cover thread carrier and hook	喂针
5.6	Looper	弯针
5.7	Needle guard (front)	前护针
5.8	Needle guard (rear)	后护针
5.9	Height of feed dog	牙齿高度
5.10	Replacing presser foot	置换压脚
5.11	Replacing presser foot spring plate	置换压脚弹簧片
5.12	Replacing and adjusting knives	置换和调整位置
6	Specifications	规格

1 · Installation 安裝

1.1 台板尺寸

1.1 Table dimensions

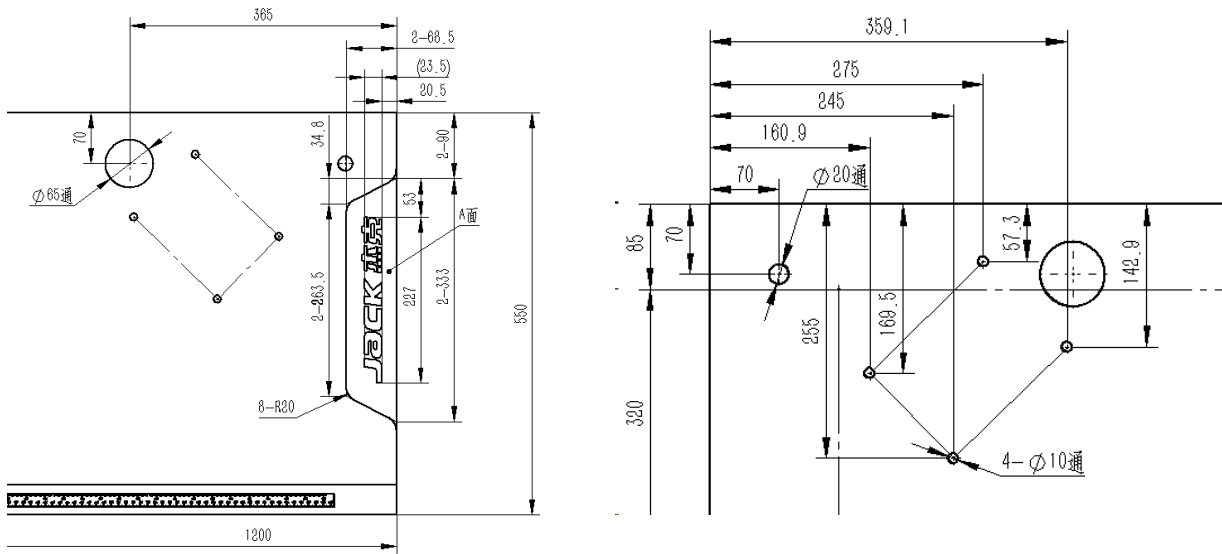

Fig.1

1.2 调整抬压脚

1.3 Adjusting presser foot lift

1.2.1 抬压脚连接杆

1.2.2 Presser foot connecting lever

设置压脚连接轴①螺钉②。(Fig.2)

Set the presser foot connecting lever① with the screw②.(Fig.2)

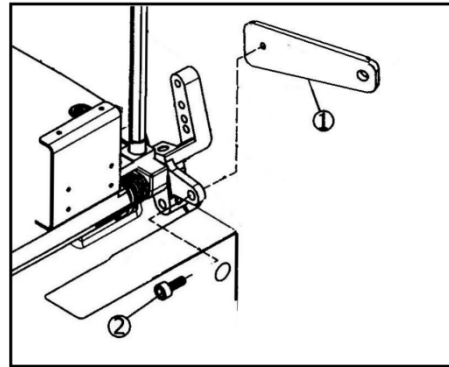

Fig.2

1 · Installation 安裝

1.2.2 抬压脚

1.2.3 Presser foot lift

1.当压脚紧贴在针板上时，在抬压脚连接轴①跟压脚连接托架②留 1mm的间隙。(Fig.3,4)

注:压脚主体跟压脚弹片之间要有 0.3mm的间隙。

1 As standard, make the clearance between the presser bar lifter lever ① and the presser bar connecting bracket ② to 1 mm when the presser foot touches the stitch plate closely.(Fig. 3,4)

Note: The clearance between the body of the presser foot and presser foot spring plate has 0.3mm

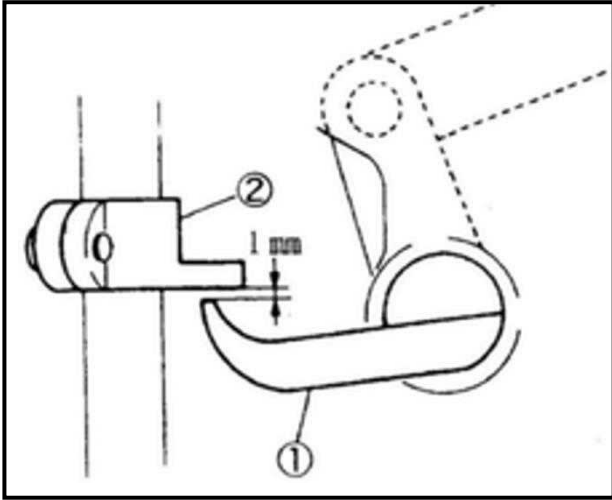

Fig.3

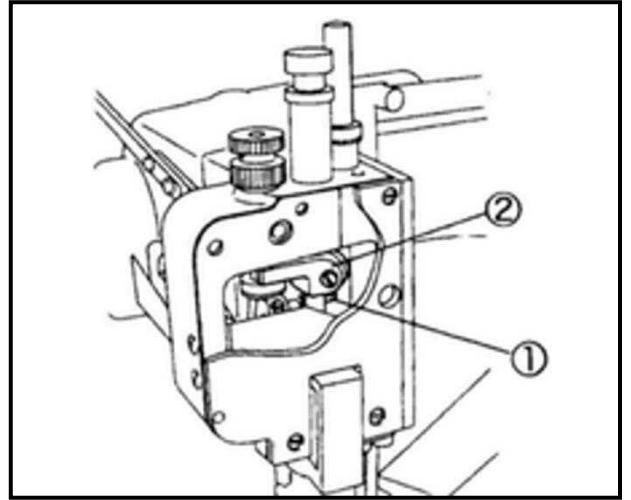

Fig.4

1 · Installation 安裝

調整：

- (1) 移除油塞③④才可以检查间隙。(Fig.5)
- (2) 放松压脚连接杆螺钉⑤。(Fig.6)
- (3) 移开压脚连接杆螺钉（短）⑥右边或左边去调整间隙。

Adjusting :

- ① Remove the seal plugs ③ ④ to check the clearance.(Fig. 5)
- ② Loosen the screw ⑤ of the presser foot lifter lever link (long). (Fig. 6)
- ③ Move the presser foot lifter lever link (short) ⑥ right or left to adjust the clearance.

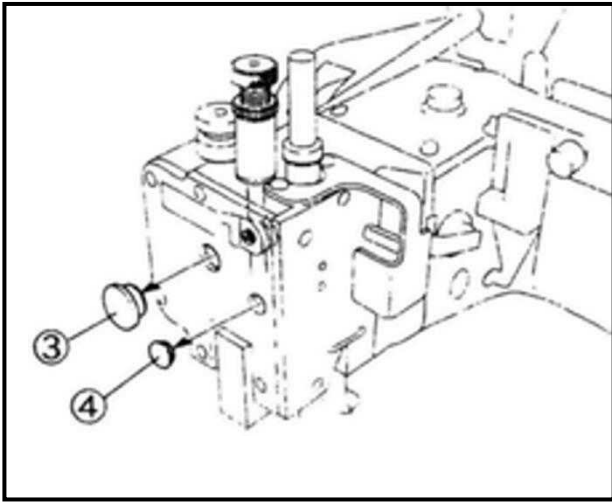

Fig.5

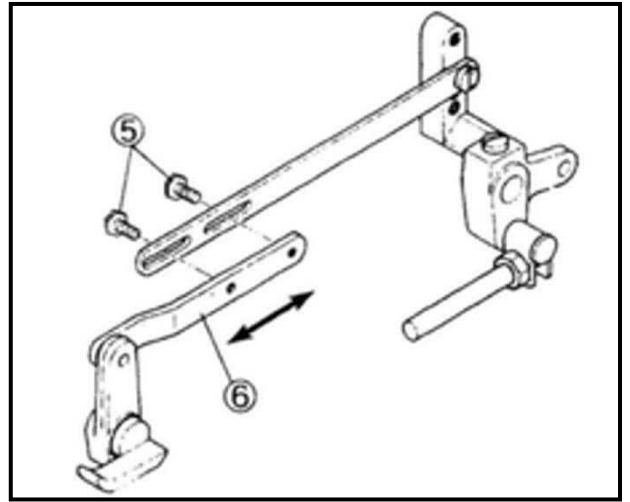

Fig.6

注意：

在调整抬压脚连接轴①之后，调整抬压脚在压脚的最低位置，如果没有调整，会导致喂针损坏。

WARNING

After adjusting the clearance of the presser bar lifter lever ① , adjust the presser foot lift at the lower point of the presser bar. If not adjusted, it can cause damage to the top cover thread hook.

1 · Installation 安裝

2 当针杆在最低位置和压脚完全抬起时，针舌①和喂针②需留间隙0.3mm。(Fig.7)

2. As standard , make the clearance between the notch of the needle clamp ① and the top cover thread hook② to 0.3mm when the needle bar is at the lowest point and the presser foot is raised by pressing the presser foot pedal fully. (Fig. 7)

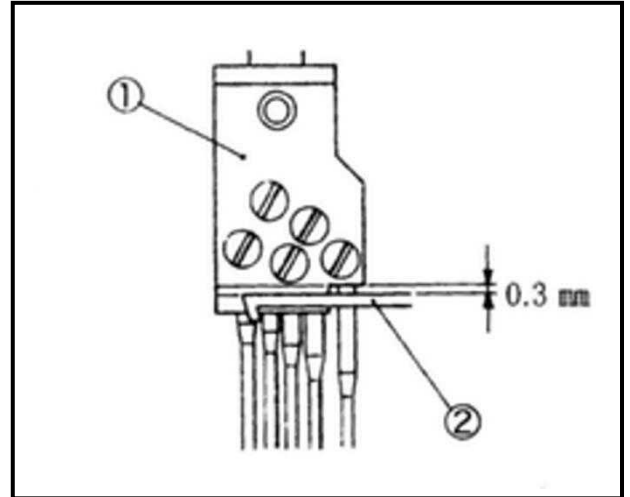

Fig.7

调整：

1 放松螺母③。(Fig.8)

2 移动抬压脚停止销④或再调整外面间隙。

Adjusting :

1 Loosen the lock nut ③ . (Fig.8)

2 Move the presser foot lifter stop plunger ④ in or out to adjust the clearance.

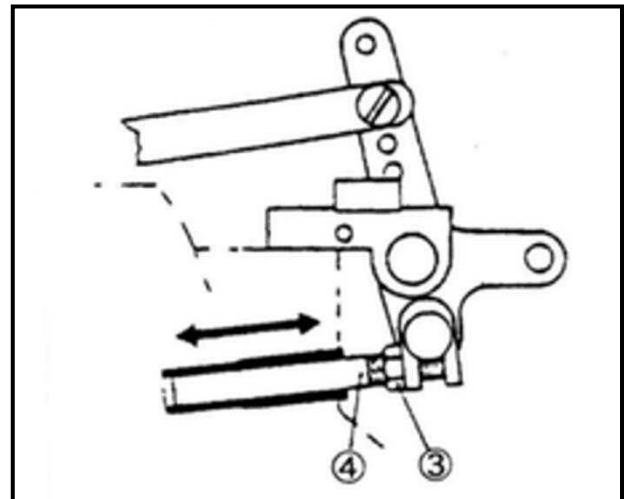

Fig.8

1 · Installation 安裝

过线组件

1.2.3 Tension release unit

不睬踏板时松线器①和松线器座之间要有0.5mm间隙。
当踩下踏板时，六个松线器①会向上推，之后上夹线片②开始离开下夹线片。(Fig.9)

As standard, make the clearance between the tension release pins ① and the tension release shaft ③ to 0.5mm when six tension release pins ① are pushed up slightly and the upper thread tension disc without pressing the presser foot pedal. (Fig.9)

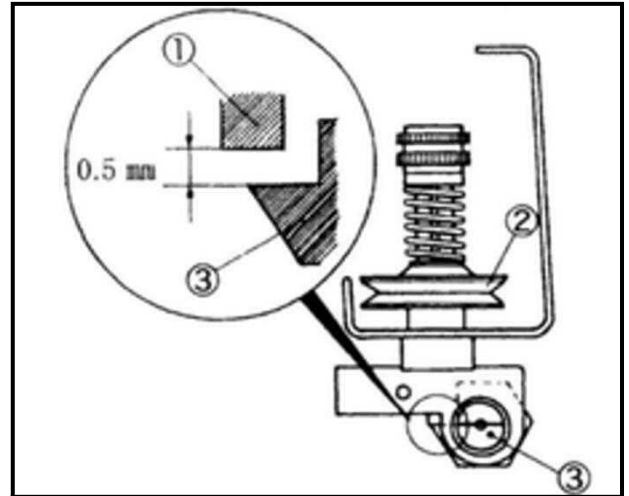

调整：

(1) 放开提升摆臂（大）的螺钉④。(Fig.10)

(2) 翻转松线器座③用螺丝刀。(Fig.9)

注：

顺时针旋转，减小间隙。

逆时针旋转，增加间隙。

Adjusting:

(1) Loosen the screw ④ of the presser bar lifter lever (large).(Fig. 10)

(2) Turn the tension release shaft ③ with a screwdriver.(Fig.9)

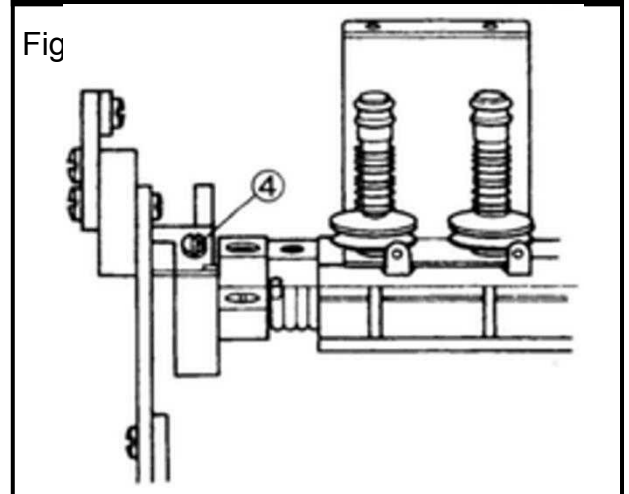

Fig.10

- To decrease the clearance, turn it clockwise.
- To increase the clearance, turn it counterclockwise.

1 · Installation 安裝

1.3 其他部分

1.3 Other parts

机头线架

将线架支柱③安装线上架固定座⑦，再将过线架④用螺钉⑤锁紧线上架支柱③上，调整过线杆⑥，使穿线平顺，不会发生纠缠。(Fig.12)

Setting thread eyelets:

Stand the thread guide plate supports③ on the thread tension support⑦ and fix the thread guide plate④ on the supports③ with the screws⑤.

Adjust the thread pipes⑥ to thread smoothly without entangling. (Fig. 12)

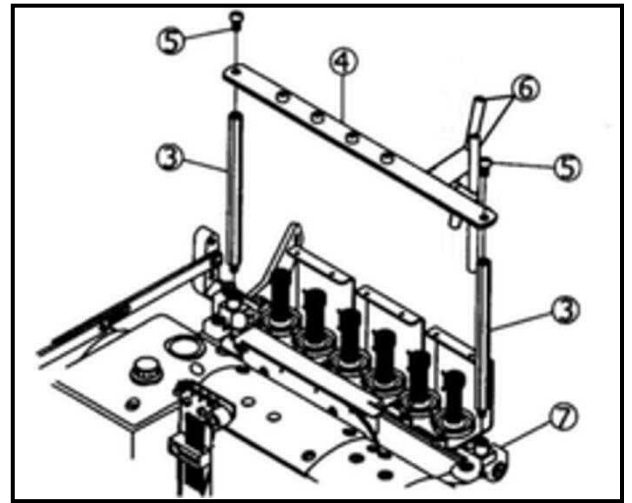

Fig.12

2 · Sewing speed and rotating direction 电机转速和方向

机器最高转速为3200rpm，平时使用2600rpm。

在前200个小时（约一个月）使用2600-2700rpm左右的速度。

The sewing speed is 3200 rpm at the maximum and 2600rpm is usual.

Run a new machine at a speed of 15-20% lower than maximum sewing speed during the first 200 hours (for about one month) .

注意：

如果运转方向相反，油无法供给，会造成机器损坏。

CAUTION

If rotating in reverse direction, oil can not be supplied properly. It can cause the machine damage.

3 · Lubrication 润滑

3.1 润滑油

3.1 Lubricating oil

注意：

绝对不要在油内加入任何添加物（剂），否则将会恶化油的品质，并损害机器。

CAUTION

Never add additives to the oil.

If added, it can cause the deterioration of the oil and the machine damage.

3.2 润滑系统

3.2 Lubricating

- (1) 旋开油塞螺钉①和②然后加油。(Fig.13)
 - (2) 从油孔①加油直到油量达到③最上方的红线，从油孔②加油直到油量到④最上面的红线。(Fig.14)
 - (3) 使用机器前检查油水平。如果没有达到水平线要加油。
 - (4) 当机器在使用中时，从油镜⑤和⑥检查油有无供应。
- (1) Remove the plug screws ① and ② indicated "OIL" and supply oil.
 - (2) From the plug screw ①, supply oil until the oil level indicator top reaches the upper line in the oil sight gauge ③. From the plug screw ②, supply oil to the upper line in the oil sight gauge ④. (Fig.14)
 - (3) Check the oil level between the lines in the oil sight gauge ③ and ④ before running a machine. If it is under the lines, supply oil.
 - (4) Check the oil splashes from the nozzle inside the oil sight top windows ⑤ and ⑥ when starting to run a machine.

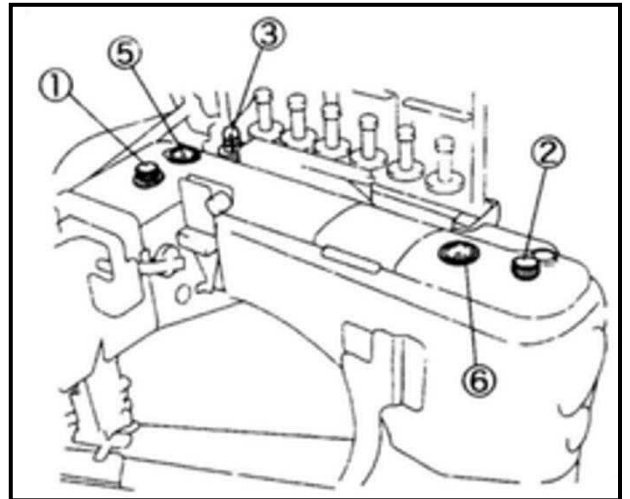

Fig.13

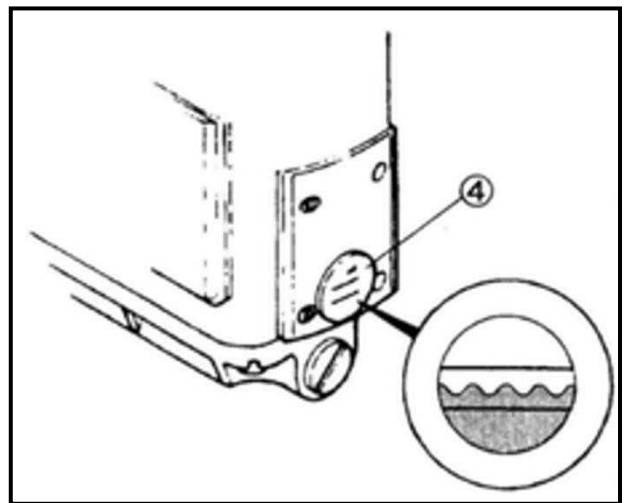

Fig.14

3 · Lubrication 润滑

注意：

太多或太少的油会造成机器漏油或故障。维持油的水平在2条红线之间。

CAUTION

Too much oil or not enough oil can cause oil leakage and machine trouble. Be sure to keep the oil level between the lines.

3.3 启动注油

3.3 Priming oil

装新机器或使用后久未使用的机器，如果油没有循环完整，需要移除机器上的油塞螺钉①，注入油后装回螺钉再使用机器。(Fig.15)

Prime oil if oil does not circulate completely when installing a new machine or running a machine which has not been used for a while.

Remove the plug screws ① of the pump driven gear to prime oil. Run a machine after resetting them ①. (Fig.15)

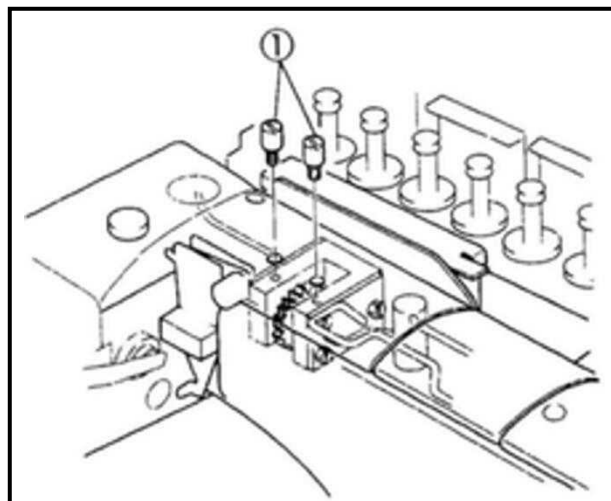

Fig.15

3 · Lubrication 润滑

3.4 补充油

3.5 Replenishing oil

在箭头处需要滴一些润滑油。如果油漏在压脚和上刀周围会沾在布上，要将油清理干净。(Fig.16,17,18)

Replenish a drop of oil from the points indicated

arrows with an oiler (accessories) if needed.

If oil leaks around the presser foot and the upper knife, it can cause oil stain on the material. Be sure to wipe

it completely. (Fig.16,17,18)

Fig.16

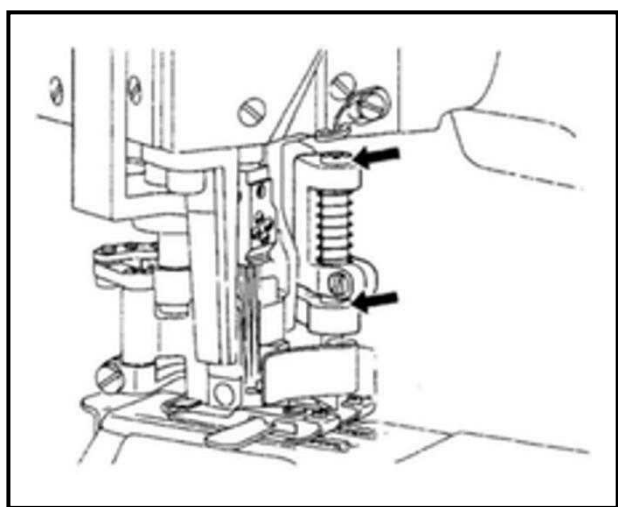

Fig.17

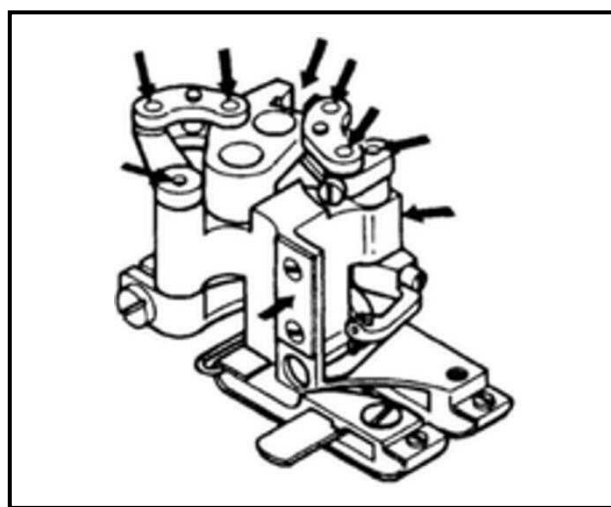

Fig.18

3.5 更换油

3.6 Changing oil

换油时间

新机使用200小时（约一个月）后，要更换新油，之后每年更换1-2次。

3.5.1 Period of changing :

When using a new machine, change the lubricating oil after running for 200 hours(for about one month). After that, change the oil once or twice a year.

3 · Lubrication 润滑

3.5.2 换油程序

- (1) 分别在螺丝①和②下面放置接油容器。
- (2) 拆下螺丝①和②后油会自行流出。
- (3) 装回螺丝①和②。
- (4) 注入新油。

Procedrue for changing :

- (1) Set containers received the oil under the screws
① and ② respectively.
- (2) After removing screws ① and ② ,the oil is drained.
- (3) Reset the screws ① and ② .
- (4) Fill the new oil.

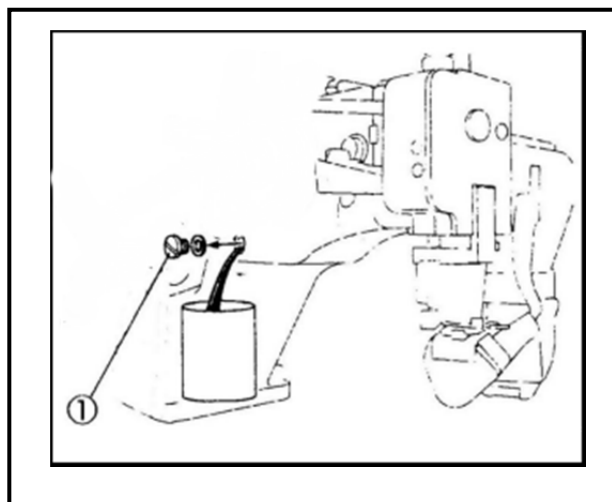

Fig.19

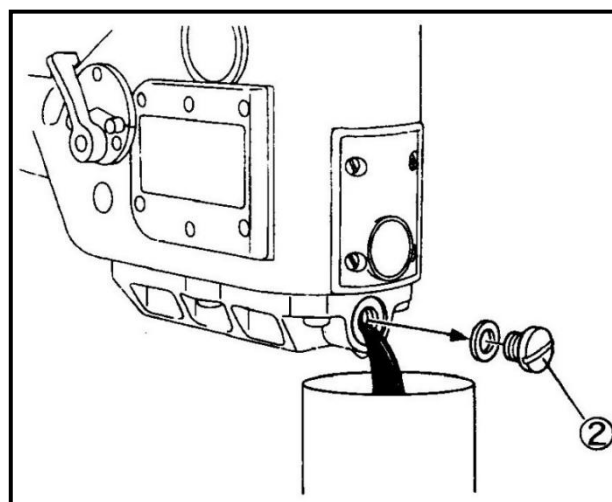

Fig.20

4. Proper operation 使用说明

4.1 车针系列

4.1 Needle system

4.1.1 缝纫机用针

4.1.1 Sewing needle :

格洛兹贝克牌(Groz-Beckert) UY118GKS
风琴牌(Organ) FLX118GCS

Japanese standard 日本规格	8	9	10	11	12	14
Metric Standard 公制规格	60	65	70	75	80	90

表格二

提醒：

请选用适合的针给不同的材料。有些尺寸并没有贩售, 请从目录上确认尺寸。

4.1.2 假针

4.1.2 Retainer needle :

四支针配合一支假针。

One retainer needle is used with four sewing needles.

格洛兹贝克牌(Groz-Beckert) 36211 , 36211A
风琴牌(Organ) FLG-1 , FLG-8

Japanese standard 日本规格	8	9	10	11	12
Metric Standard 公制规格	60	65	70	75	80

表格三

提醒：

请选用适合的假针去使用不同的材料。有些尺寸并没有贩售, 请从目录上确认尺寸。

Note:

Select the proper sewing needle in size depending on thickness and type of material.

4. Proper operation 使用说明

4.2 针的安装

4.2 Installing needle

- (1) 旋转转轮将针抬到最高点.
 - (2) 放松螺丝①。(Fig. 21)
 - (3) 平面摆在前方将新针放入针箍内最顶端, 然后锁紧螺丝①。
- (1) Rotate the handwheel to raise the needles at the highest point.
 - (2) Loosen the screws① and pull the needles down.
 - (3) Face the flat parts front, insert new needles into the needle clamp as far as they will go. Tighten them with the screws① securely.

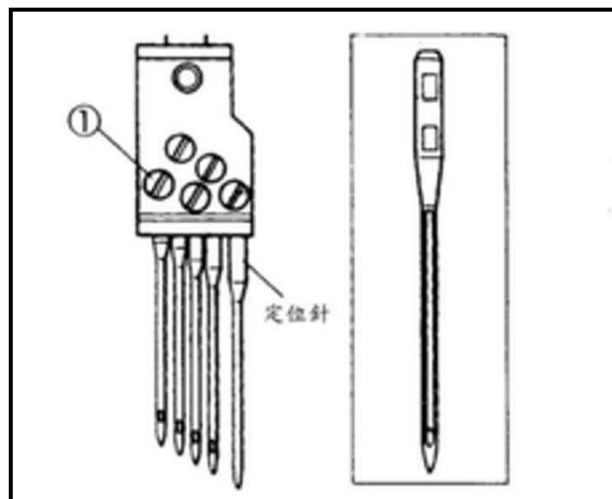

Fig.21

注意：

在调整机器前，一定要先把电源关掉，并确定电机完全停止。

WARNING

Before installing the needles, always turn the motor switch OFF and check that the motor has already stopped.

4. Proper operation 使用说明

4.3 线

4.3 Threading

先用易穿的线从ABCDEF 孔穿至针镙前, 然后结上要用的线拉到针前, 把结剪掉。正确位置(Fig. 28)。

a , b , c , d:针线e:

上饰线

f:下勾针线

When threaded, pull the thread out until it is in front of the needles. Then cut off the knot before needle eye to rethread. When threaded, pull the thread out until the knot is out. Then cut off the knot.

A, B, C, D : Needle thread

E : Top cover thread

F : Lower looper thread

提醒 :

当抬起压脚时, 线架组会平稳的放开, 此时可轻松的将线拉过。穿下钩针线时不须把针板拆掉。

Note:

When raising presser foot, thread tension will be released to take up smoothly.

Improper threading can cause thread breakage, skip stitch, and uneven stitch.

注意 :

在调整机器前, 一定要先把电源关掉, 并确定电机完全停止。

WARNING

Before threading, always turn the motor switch OFF and check that the motor has already stopped.

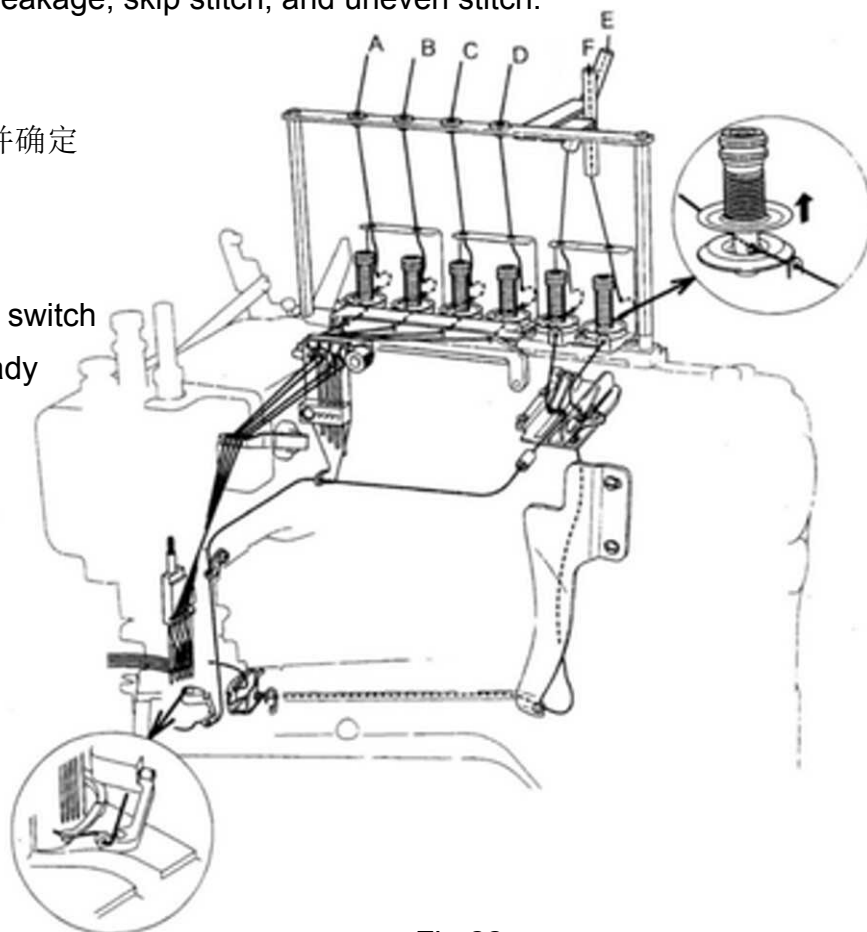

Fig.22

4. Proper operation 使用说明

4.4 线松紧

4.4 Thread tension

调整线架上的松紧度是靠螺母① -⑥ 取决于布线宽度和其它状况。(Fig. 29)

① -④ : 针的线(① : 右针, ④ : 左针)

⑤ : 上网线

⑥ : 下网线

★ 如果调紧线时, 以顺时间方向调下① -⑥ 螺丝。

★ 如果调松线时, 以逆时间方向调上① -⑥ 螺丝。

Adjust the thread tension with the tension adjusting

nuts ① -⑥ depending on fabric type, thread type, seam width, stitch length, and other sewing conditions.

① -④ : needle threads (① : right needle, ④ : left needle)

⑤ : top cover thread

⑥ : looper thread

● To tighten the thread tension, turn the nuts clockwise.

● To loosen the thread tension, turn nuts counterclockwise.

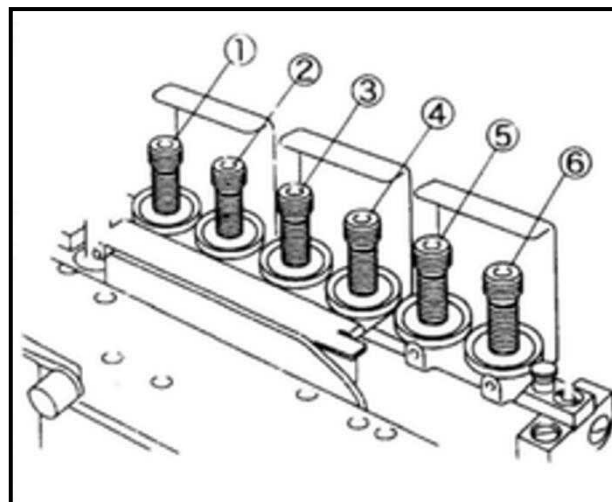

Fig.23

4.5 调整压脚压力

4.5 Pressure of presser foot

放松螺母⑦ 然后用压脚柱螺帽⑧ 来调压力。(Fig. 24)

★ 增加压脚压力时, 顺时间调整螺帽⑧。

★ 减少压脚压力时, 逆时间调整螺帽⑧。

Loosen the lock nut ⑦ and turn the adjusting screw ⑧ to adjust the pressure.

● To increase the pressure, turn the adjusting screw ⑧ clockwise.

● To decrease the pressure, turn the adjusting screw ⑧ counterclockwise.

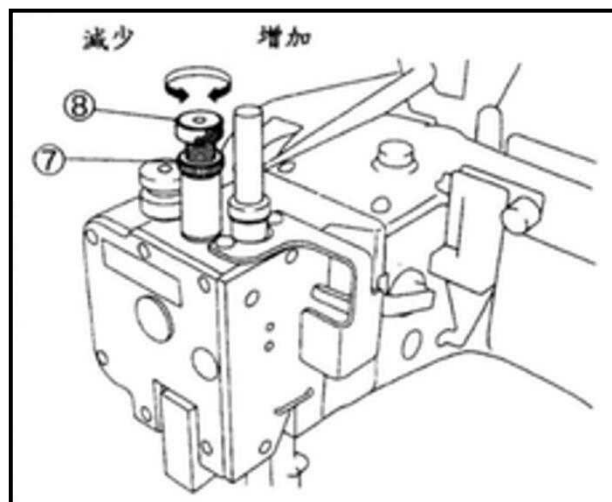

Fig.24

提醒:

尽可能保持压脚压力在最松的状态, 使布在针板上更加平稳。

Note:

Keep the pressure as low as possible for stable stitches.

4. Proper operation 使用说明

4.6 调整压脚高低

4.6 Up-and-down position of presser foot

轻微的调高或降低压脚都会有明显的成效。

Following effective points will be obtained by slightly raising the presser foot.

- ★ 预防勾齿抓痕。
- ★ 改善压脚弹片的耐久度。
- ★ 增减压脚弹片的压力度。
- ★ 减少噪音和振动。
- ★ 可细微的调整针织的宽度。
- ★ Prevention of fabric jam
- ★ Prevention of feed scratch mark
- ★ Improvement of durability of presser foot spring plate
- ★ Reduction of vibration and noise
- ★ Available for fine adjustment of lapped fabric width

(1) 针在最底点的位置。

(2) 松开螺丝①, 然后逆时间旋转调整螺母② 抬起压脚。(Fig. 25)

(3) 在压脚④和压脚弹片③ 之间调整出0.3-0.5mm 的间隙。(Fig. 26)

(4) 把螺母① 锁回去。

(1) Position the needle at the lowest point.

(2) Loosen the lock nut① and run the adjusting nut ② counterclockwise to raise the resser foot

(3) Adjust the clearance between the botton④ of the presser foot and the presser foot spring plate③ to 0.3-0.5 mm

(4) Tighten the lock nut① securely.

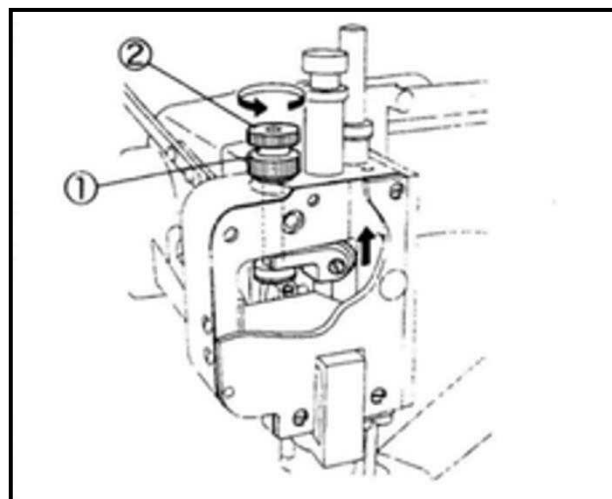

Fig.25

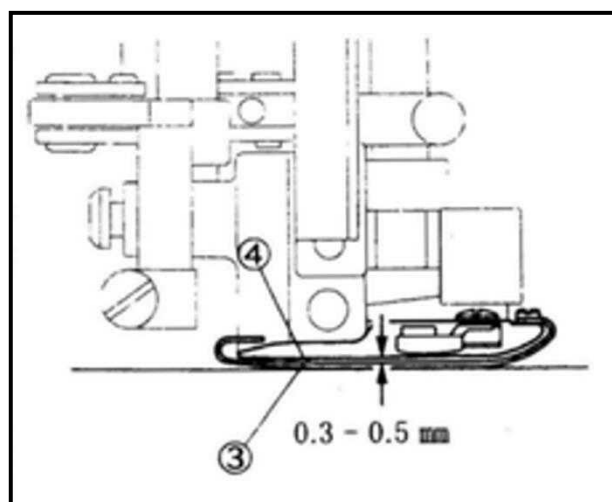

Fig.26

4. Proper operation 使用说明

4.7 调整差动

4.7 Adjusting differential feed dog

- (1) 移动调整杆向右或左去调整差动杆⑤ 在刻度 "4" 和刻度 "5" 之间是相同的动作和差动. 即主牙和差动牙的运作相同。(Fig. 27)
- (2) 螺丝⑥ 是用来固定调整杆⑤ 和保持差动的多或少。

- (1) Move the differential feed operating lever ⑤ right or left to adjust differential feed dog.

The lever ⑤ between the graduations "4" and "5" makes the equal movement of the main and the differential feed dogs.

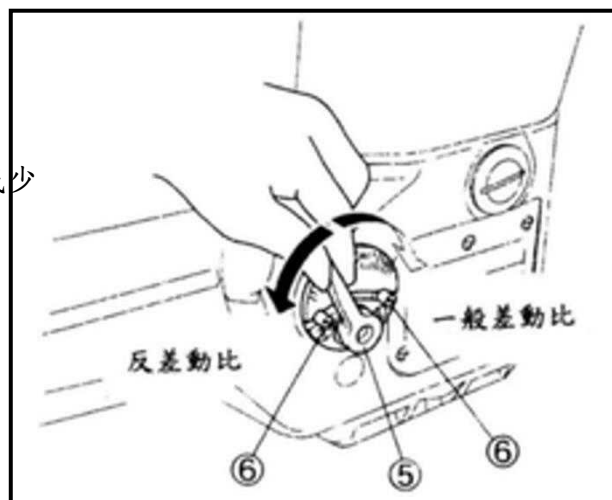

Fig.27

- (2) The screw ⑥ is for fixing the lever ⑤ and keeping the differential movement adjusted.

★ 一般差动比:调整杆⑤ 调到刻度"9"的位置。

★ 反差动比:调整杆⑤ 调到刻度"1"的位置。

★ To make normal differential, move the lever ⑤ to "9".

★ To make reverse differential, move the lever ⑤ to "1"

注意：

在调整机器前，一定要先把电源关掉，并确定电机完全停止。

WARNING

Before adjusting, always turn the motor switch OFF and check that the motor has already stopped.

4. Proper operation 使用说明

4.8 调整针距

4.8 Adjusting stitch length

粗细针的范围标准为1.6-2.5mm, 但可调整至更大. Stitch length ranges 1.6-2.5 mm as standard and can be adjustable infinitely.

调整:

- ⌘ 放松螺丝①, 移动针档②(后)到最后面. 然后轻微锁紧. 减少针宽时可以省略。
- ⌘ 退掉油塞螺丝③。
- ⌘ 放松螺丝④去调整粗细针。
- ⌘ 锁紧螺丝④和重新装上油塞螺丝①。

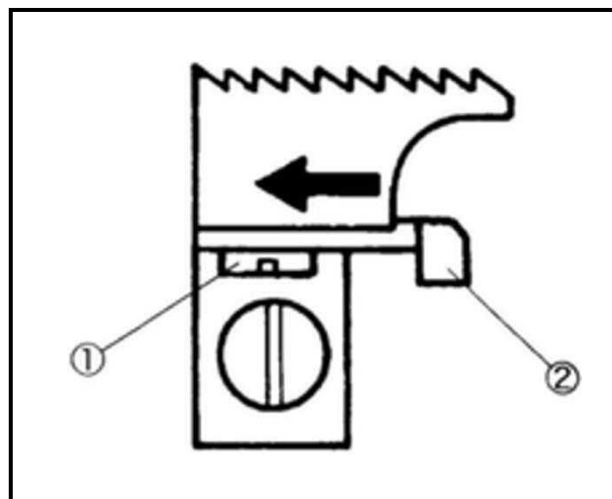

Fig.28

Adjusting :

- ⌘ Loosen the screw① and move the needle guard (rear) ② most rearward. Then tighten it slightly.
* This is skipped when decreased the stitch length.
- ⌘ Remove the plug screw③.
- ⌘ Loosen the screw④ to adjust the stitch length.
- ⌘ Tighten the screw④ securely and reset the plug screw①.

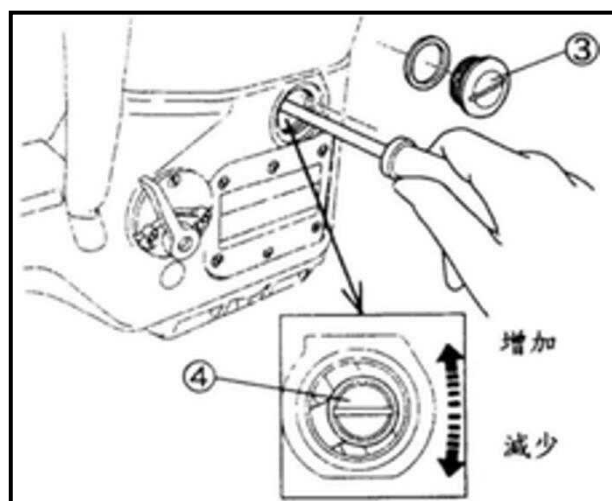

Fig.29

★ 增加针距时, 将螺丝④ 向上调整。

★ 减少针距时, 将螺丝④ 向下调整。

★ To increase stitch length, move the screw④ upward.

★ To decrease stitch length, move the screw④ downward.

注意:

油塞螺丝③ 要锁紧防止漏油。

CAUTION

Tighten the plug screw③ securely to prevent oil leakage.

4. Proper operation 使用说明

表格四为针距大小使每英寸或每30mm 的距离有几针。

Table 4 shows the number of stitches per inch (25.4 mm) and 30 mm converted stitch length.

注意：

调整针距必须注意后针档的位置。

CAUTION

Be sure to adjust needle guard(rear) after changing stitch length to prevent breakage of the parts.

针距(mm)	1 英寸针数	30mm 针数
2.5	10	12
2.1	12	14
1.8	14	16.5
1.6	16	19
1.2	21	25
表格四 ¹	25	30

提醒：

每次在更换不同的狗齿之后, 都要调整粗细针。

Advice adjustment

Always adjust stitch length after changing differential feed dog.

注意：

在调整机器前，一定要先把电源关掉，并确定电机完全停止。

WARNING

Before adjusting, always turn the motor switch OFF and check that the motor has already stopped.

4. Proper operation 使用说明

4.9 调整切布刀

4.9 Adjusting lapped width of upper fabric

(1) 底刀① 的标准位置要留距离在底刀① 尖端和锁底刀座②之间0-0.5mm。(Fig. 30)

(2) 当上刀③ 在最左边时, 上刀③ 和底刀① 要有0.5mm 的重叠。

(3) 放松螺丝④ 和⑤ 去调整上刀和底刀。(Fig.31 , 32)

(1) For the standard position of the lower knife ①, make the distance between the lower knife ① tip and the lower knife clamp ② to 0-0.5 mm. (Fig. 30)

(2) For the standard position of the upper knife ③, engage between the upper knife ③ and lower knife ① to 0.5 mm when the upper knife ③ is at the extreme left.

(3) Loosen the screws ④ and ⑤ to adjust the lower and upper knives respectively. (Fig.31 , 32)

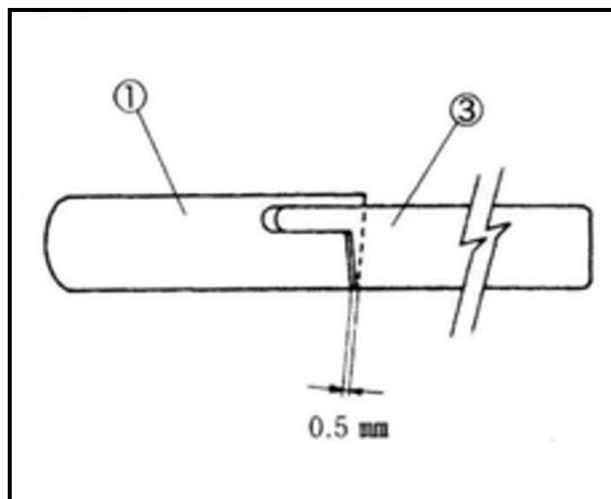

Fig.30

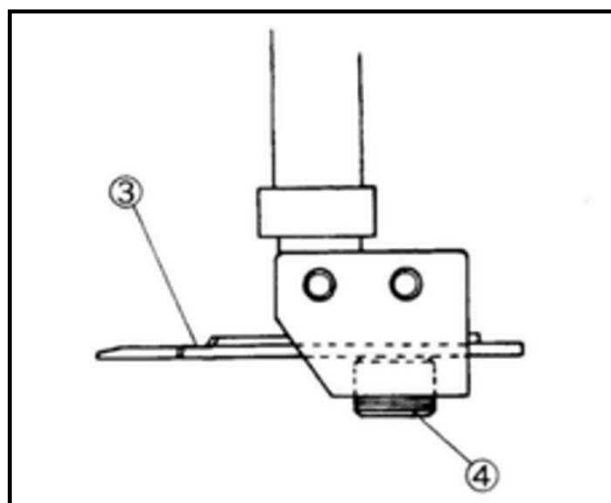

Fig.31

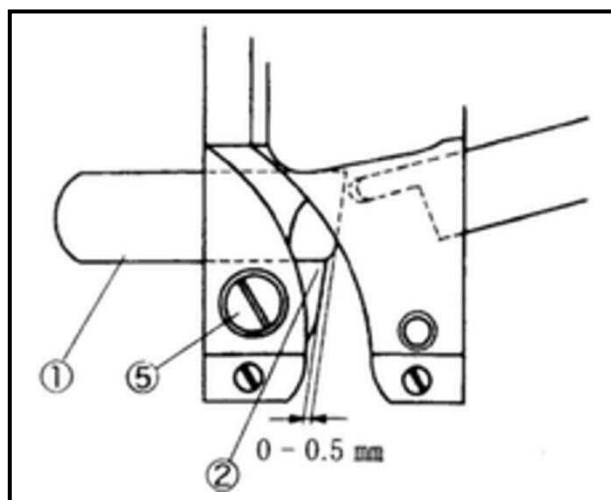

Fig.32

4 · Proper operation 使用說明

4.10 过线油组

4.10 SP device

当机器在高速运转或使用特殊线或特殊纤维时，矽油壶组是标准配备，以防止断线跳针。

当使用机器时，将毛毡①放入矽油壶②内。
(Fig.33)

SP device (needle thread oiling) is equipped as standard to prevent thread breakage and skip stitch when running a machine at high speed or using synthetic thread and/or synthetic fabric.

Fix the felts① included accessories into the SP tank② when using.

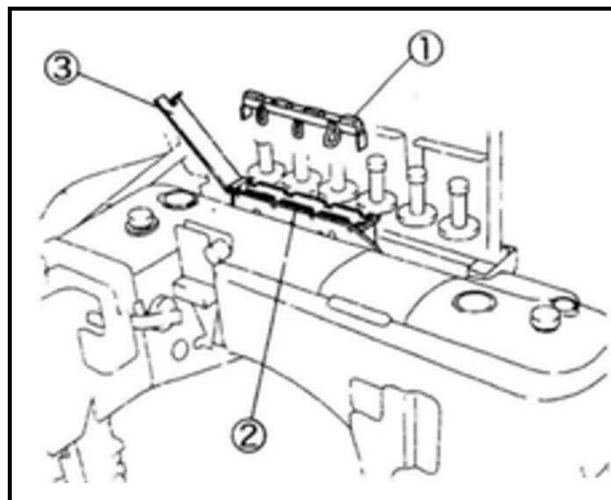

Fig.33

注意：

- 1 当不使用矽油壶组时，要取出毛毡①。不然可能在车缝时发生不正常情况。
- 2 当矽油沾到其他零件时，可能引起机器损伤，故要将油擦干净。

CAUTION

- 1 When not using SP device, remove the felts①. If not, it may occur irregular condition during sewing.
- 2 If the silicone oil stuck to the parts other than SP device, it can cause the machine damage. Be sure to wipe it away.

使用乙烷树脂

打开油壶盖③，检查油量。如果不够，添加油于油壶②。

Use dimethy 1 silicone oil

Open the oil cup lid③ and check the oil amount. If not enough, supply oil into the SP tank②.

5 · Adjustments 调节装置

5.1 针线松紧

5.1 Needle thread tension

5.1.1 针线线圈调整片

5.1.1 Needle thread strike-off pin

4 根针各有自己的过线片可调整线圈的松紧。

- (1) 抬线架①转到最低位置。(Fig.36)
- (2) 第一片②要跟右边第四根针的线平齐。(Fig.37)
- (3) 第四片③离第一片②的高度为 3.2mm。
- (4) 第三片④离第一片②的高度为 1.6mm。
- (5) 第二片⑤离第一片②的高度为 0.8mm。
- (6) 对准后锁紧螺钉⑥。

注：检查最上面那片水平。

★ 要把线圈变大就把过线片往上移“L”。

★ 要把线圈变小就把过线片往下移“S”。

Each of four needles has the needle thread strike-off pin which adjusts the thread tension respectively.

- (1) Position the needle thread take-up① at the lowest point. (Fig.36)
- (2) Set the top of pin② even with the needle thread as the fourth right needle. (Fig.37)
- (3) Set the pin③ 3.2 mm higher than the pin②.
- (4) Set the pin④ 1.6 mm higher than the pin②.
- (5) Set the pin⑤ even with or 0.8 mm higher than the pin②.
- (6) Tighten the screws⑥ securely.

Note: Check the tops of the pins are horizontally.

★ To make the loop larger, move the pins in the direction“L”.

★ To make the loop smaller, move the pins in the direction“S”.

注意：

在调整机器前，一定要先把电源关掉，并确定电机完全停止。

WARNING

Before adjusting, always turn the motor switch OFF and check that the motor has already stopped.

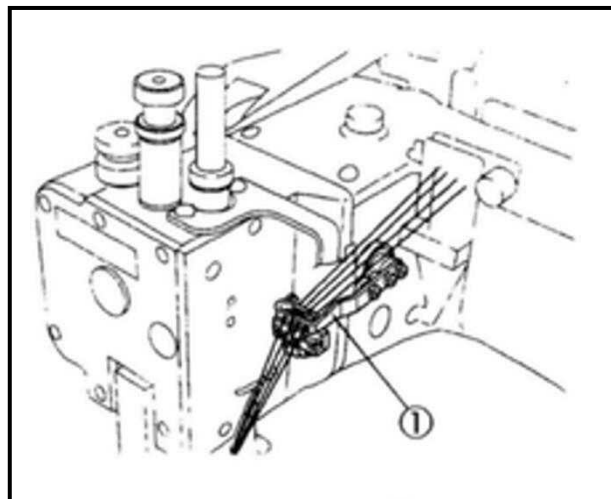

Fig.36

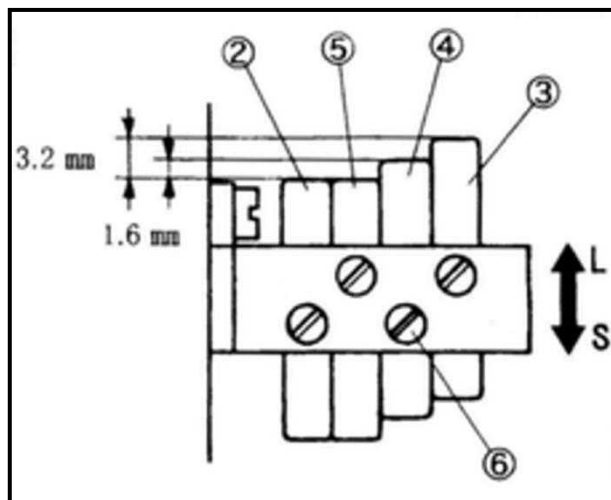

Fig.37

5 · Adjustments 调节装置

5.1.2 针线孔

5.1.2 Needle thread eyelet

(1) 右边最高的过线孔①要跟线孔③成一条线。

(Fig.38)

(2) 过线孔④比①低 5mm。

(3) 过线孔⑤比①低 9mm。

(4) 过线孔⑥比①低 15mm。

★ 过线片往下移，线就会变紧。

★ 过线片往上移，线就会变松。

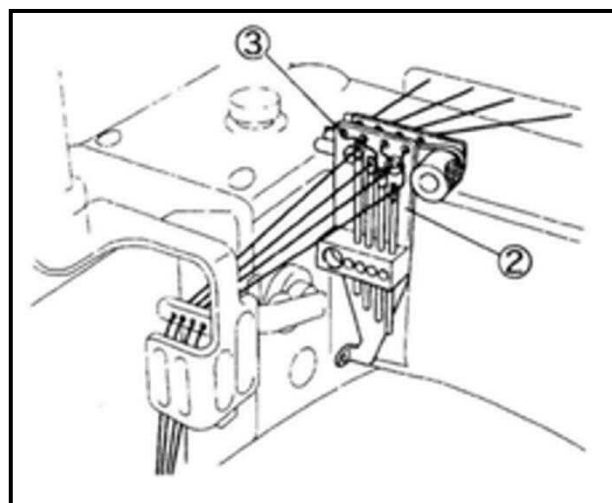

Fig.38

(1) Make the height of the right needle thread

eyelets① to align their eyes with the eyes③ of the needle thread eyelet holder.

(2) Set the eyelet④ 5 mm lower than the eyelet①.

(3) Set the eyelet⑤ 9 mm lower than the eyelet①.

(4) Set the eyelet⑥ 15 mm lower than the eyelet①.

★ To tighten needle thread, move the eyelets in the direction "T".

★ To loosen needle thread, move the eyelets in the direction "L".

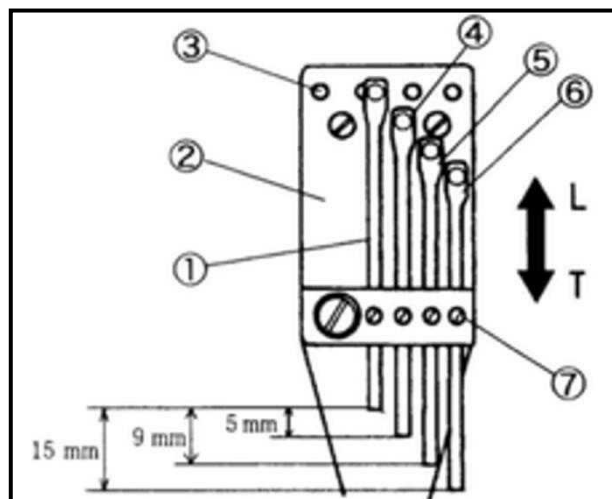

Fig.39

注意：

在调整机器前，一定要先把电源关掉，并确定电机完全停止。

WARNING

Before adjusting, always turn the motor switch OFF and check that the motor has already stopped.

5 · Adjustments 调节装置

5.2 弯针线

5.2 Looper thread tension

底线导板①和支撑②要成一条线。

Align the right of the looper thread take-up guide① with that of the eyelet supporting plate②.

5.2.1 弯针线收紧时机

5.2.1 Timing of looper thread take-up

正确的凸轮④位置是当针杆③最高的位置下移2.8mm时，线通过A点。放松⑤去调整。

Position the looper thread take-up④ as standard so that looper thread passes at the point A when the needle bar③ is lowered 2.8 mm from the highest point. Loosen the screws⑤ to adjust it.

★ 增加弯针线的松度，把打线凸轮调快。
减少弯针线的松度，把打线凸轮调慢。

★ To increase the looper thread take-up amount, hasten the timing.

★ To decrease the looper thread take-up amount, delay the timing.

注：当调整弯针凸轮④时，面向凸轮④突出的地方和上线抬起时不用不用调整前后位置。

Note : When adjusting take-up④, face both bosses of the take-up④ and the top cover thread take-up without shifting the front-and-rear position.

注意：

如果时间差调超过会造成跳针。

CAUTION

If the timing of the looper thread take-up exceeds the adjustable range, it may occur skip stitch.

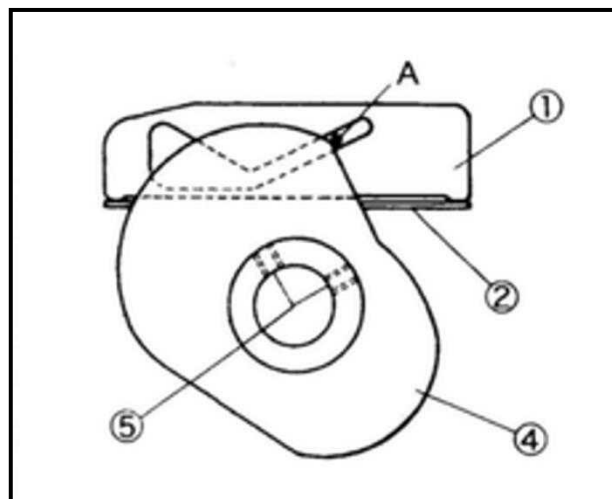

Fig.40

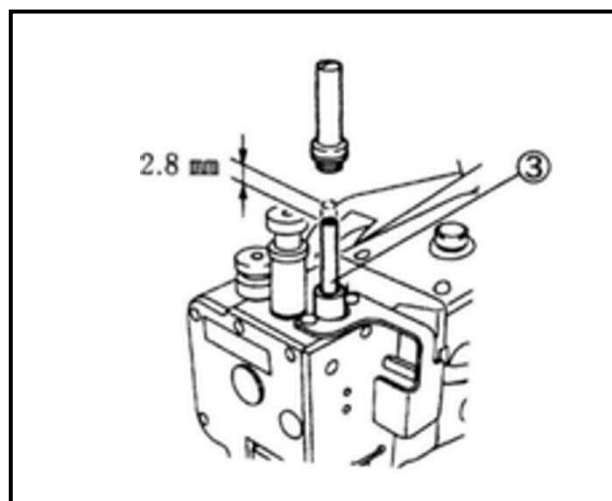

Fig.41

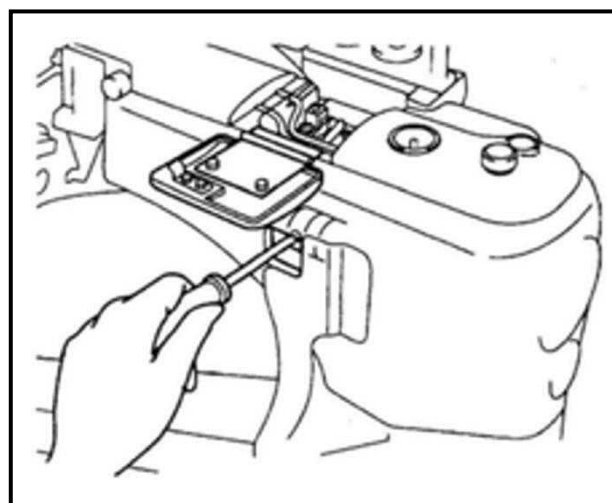

Fig.42

5 · Adjustments 调节装置

5.2.2 弯针凸轮位置

5.2.2 Position of looper thread take-up eyelet

底线过线片⑥和⑦标准位置为最右边。放松螺钉

⑧和⑨左右移动去调整。(Fig.43)

Set the looper thread take-up eyelets ⑥ and ⑦ at the extreme right as standard.

Loosen the screws ⑧ and ⑨, and move them right or left to adjust ti.

★ 增加弯针线的量，将过线片往“L”的方向移动。

★ 减少弯针线的量，将过线片往“S”的方向移动。

★ To increase the looper thread take-up amount, move them in the direction “L”.

★ To decrease the looper thread take-up amount, move them in the direction “S”.

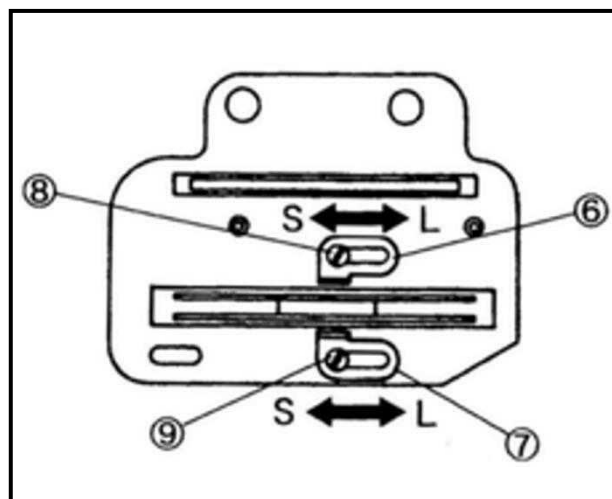

Fig.43

注意：

在调整机器前，一定要先把电源关掉，并确定电机完全停止。

WARNING

Before adjusting, always turn the motor switch OFF and check that the motor has already stopped.

5.3 喂针线

5.3 Top cover thread tension

5.3.1 线孔位置

5.3.1 Position of thread take-up eyelet

支撑板②和过线片①的标准距离是 4.4mm。放松

螺钉③再上下调整移动线孔。(Fig.44)

★ 增加线量时，将过线片①往下移。

★ 减少线量时，将过线片①往上移。

Make the standard distance from the top the eyelet supporting plate ② to the thread take-up eyelet ① eye

to 4.4 mm.

Loosen the screw ③ and move the eyelet ① up or down to adjust it.

★ To increase the top cover thread take-up amount, move the eyelet ① downward.

★ To decrease the top cover thread take-up amount, move the eyelet ① upward.

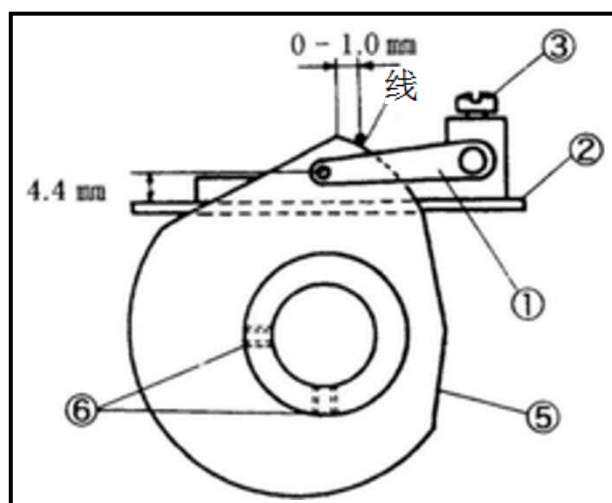

Fig.44

5 · Adjustments 调节装置

5.3.2 调整喂针线的时机

5.3.2 Timing of top cover thread take-up

当大的喂针④勾到小喂针上的线时(Fig.45), 喂针线和凸轮的尖端的距离为 0-1.0mm 之间, 调整凸轮⑤时松开螺钉⑥。(Fig.44)

The moment the top cover thread is hooked with the top cover thread hook④ (Fig. 45), the thread is held at the point 0-1.0 mm apart from the top of the take-up⑤. Loosen the screws⑥ to adjust it. (Fig.44)

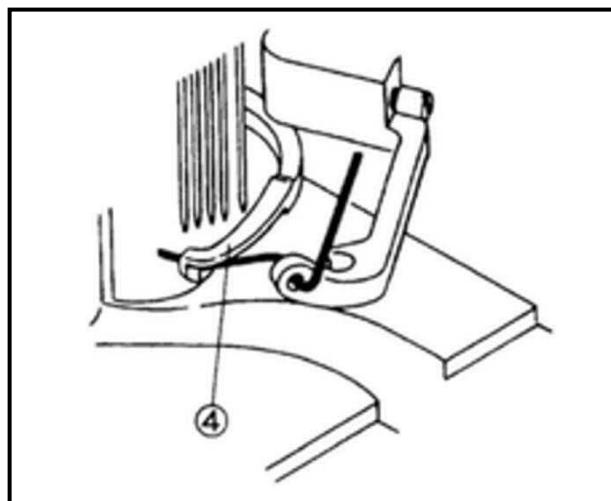

Fig.45

注：调整好凸轮⑤时，勾线时间和凸轮⑤时间正确时，不必在前后调整。

Note : When adjusting take-up⑤, face both bosses of the take-up⑤ and the looper thread take-up without shifting the front-and-rear position.

注意：

在调整机器前，一定要先把电源关掉，并确定电机完全停止。

WARNING

Before adjusting, always turn the motor switch OFF and check that the motor has already stopped.

5 · Adjustments 调节装置

5.4 机针高度

5.4 Height of needle

第四根机针和针板的距离为“N”的高度，但针距大小不同，高度就不同，如表格五所示。

Make height “N” of the needle from the top of the stitch plate to the tip of the fourth needle from the left when the needle is at the highest point.

针距 Needle distance	高度(N) Height(N)
R : 5.2mm	13.5mm
S : 6.0mm	12.7mm

表格五

调整高度：

- (1) 移开油塞①。
- (2) 松开螺钉②。
- (3) 上下移动针杆③去调整，针与针孔需保持平行。(Fig.48)
- (4) 锁紧螺钉②。
- (5) 装回油塞①。

Adjusting height :

- (1) Remove the seal plug①.(Fig.47)
- (2) Loosen the screw②.
- (3) Move the needle bar③up or down to adjust the height. Check the alignment in Fig. 48.
- (4) Tighten the screw②scecruely.
- (5) Reset the seal plug①.

注意：

在调整机器前，一定要先把电源关掉，并确定电机完全停止。

WARNING

Before adjusting, always turn the motor switch OFF and check that the motor has already stopped.

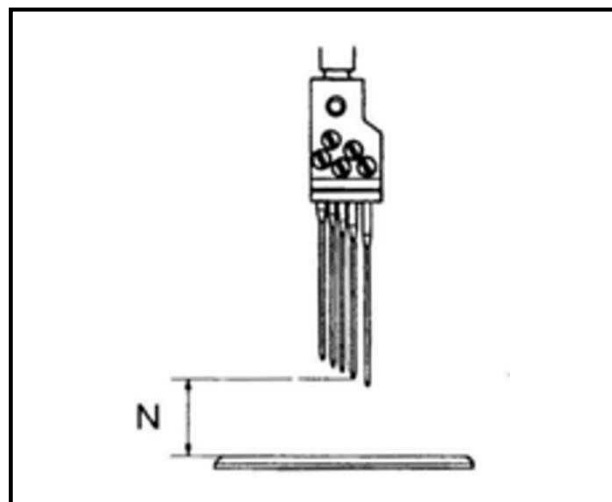

Fig.46

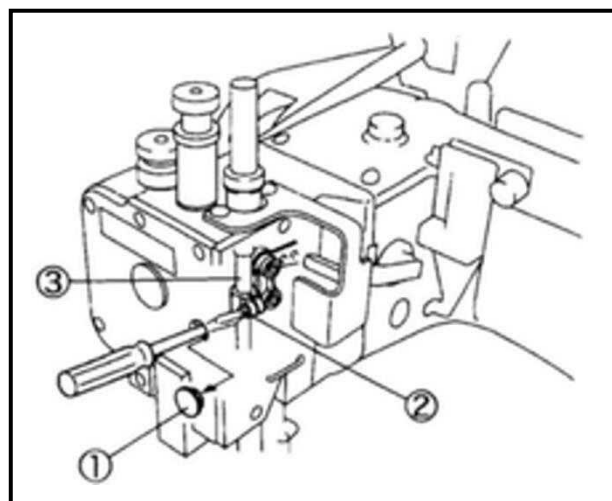

Fig.47

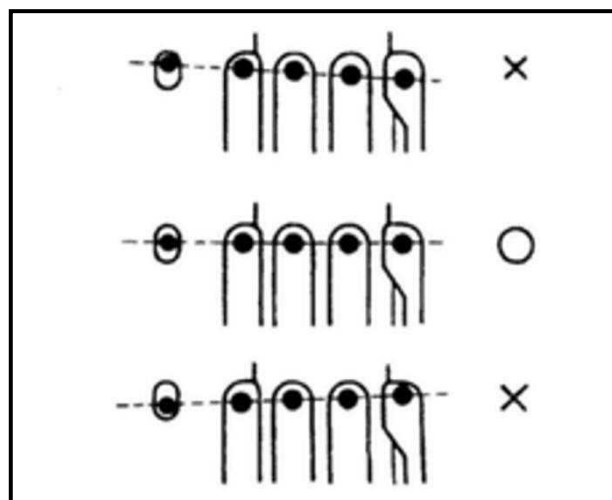

Fig.48

5 · Adjustments 调节装置

5.5 喂针

5.5 Top cover thread carrier and hook

喂针线的时间点：

调整喂针位置形成线圈，使第一根机针和第二根机针插入线圈内，放松螺钉⑤调整喂针①。

(Fig.49)

Top cover thread carrier :

Position the top cover thread carrier① so that top cover thread loop formed with the hook behind the first and the second needles from the left when the carrier① comes most nearly to the needle.

Loosen the screw⑤ to adjust it.

喂针：

当大喂针②和小喂针①最接近时的间隙为 0.4-0.7mm。(Fig.50)

当大喂针②停在最右边时，和假针③要有 0.5mm 的间隙。(Fig.52)

放松螺钉⑥去调整。(Fig.51)

Top cover thread hook :

When the top cover thread hook② comes most nearly to the top cover thread carrier③, make the clearance between them to 0.4-0.7 mm during one rotation. (Fig.50)

When the hook② moves at the extreme right, make the clearance between the hook② and the retainer③ to 0.5 mm. (Fig.52)

Loosen the screw⑥ to adjust them. (Fig.51)

注：要调整时不要抬压脚上下。

Note : Be sure adjust them without play up and down.

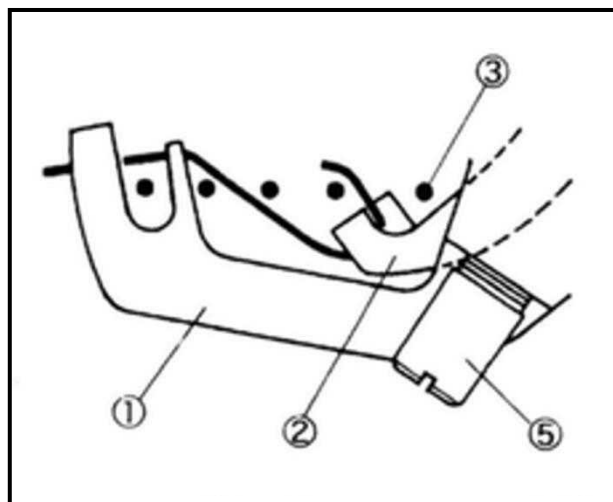

Fig.49

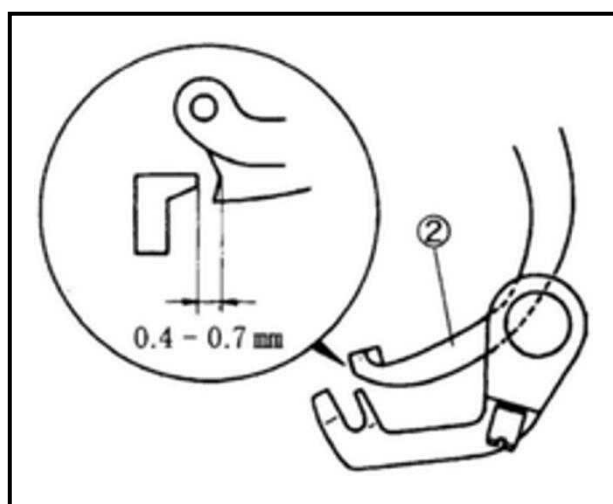

Fig.50

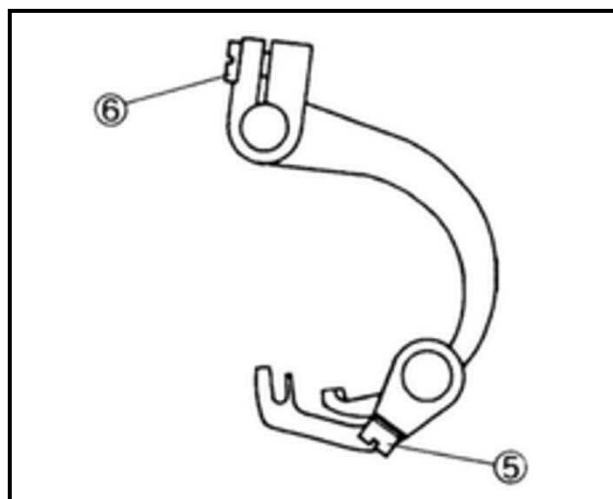

Fig.51

5 · Adjustments 调节装置

注意：

在调整机器前，一定要先把电源关掉，并确定电机完全停止。

WARNING

Before adjusting, always turn the motor switch OFF and check that the motor has already stopped.

Fig.52

5.6 弯针

5.6 Looper

高度：

装弯针①到弯针座上⑥然后锁紧螺钉②。

Height :

Insert the looper① into the hole of the looper holder⑥ and tighten the screw② securely.

角度：

弯针固定座平面 A 要和弯针柱成 90 度。放松螺钉②去调节弯针。

Angle :

Fix the surface A of the looper at 90° to the looper rocker shaft. Loosen the screw② to adjust it.

弯针和机针距离：

当弯针在最左边时，弯针和机针的标准距离为 4.2-4.8mm。客房松螺钉④去调整。

Distance between looper and needle :

Make standard distance between the looper tip and the center of the left needle to 4.2-4.8 mm when the looper① is at the extreme left.

Loosen the screw④ to adjust it.

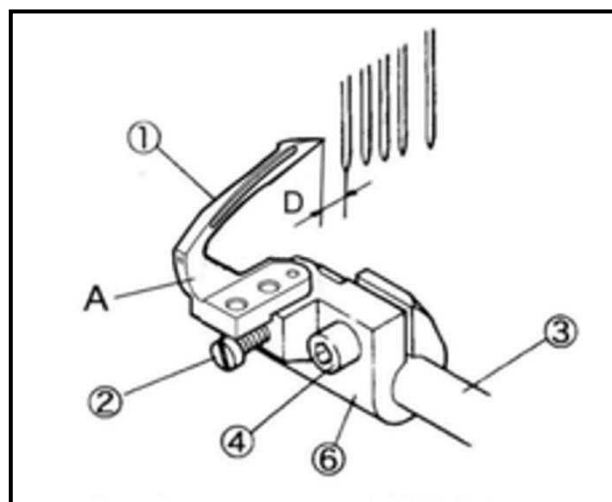

Fig.53

5 · Adjustments 调节装置

弯针前后位置：

当弯针①移动从左到右，会在真的后面。调整其位置使弯针更接近机针，其间隙 0-0.05mm，但不能碰到机针，当弯针的尖端在左针中间时，放松螺钉④转动螺钉⑤调整前后位置。调整之后检查间隙和锁紧螺钉④。(Fig.54 , 55)

★ 顺时针旋转螺钉⑤会往前。

★ 逆时针旋转螺钉⑤会往后。

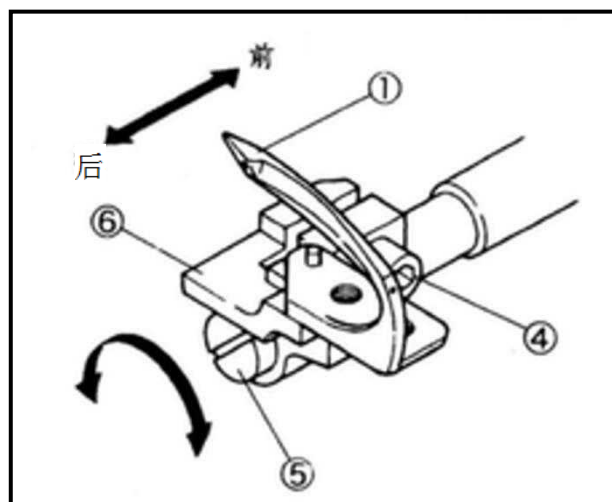

Fig.54

Front-and-rear position of looper and needle:

When the looper① moves from the left to the right, it passes behind the needle. Adjust the position so that the looper comes closely to the needle with the clearance of 0-0.05 mm but without touching them when the looper tip comes at the center of the left needle. Loosen the screw④ and turn the adjusting screw⑤ to adjust it. After adjusting, check the distance and tighten the screw④ securely. (Fig.54,55)

● To move forward, turn the screw⑤ clockwise.

● To move backward, turn the screw⑤ counterclockwise.

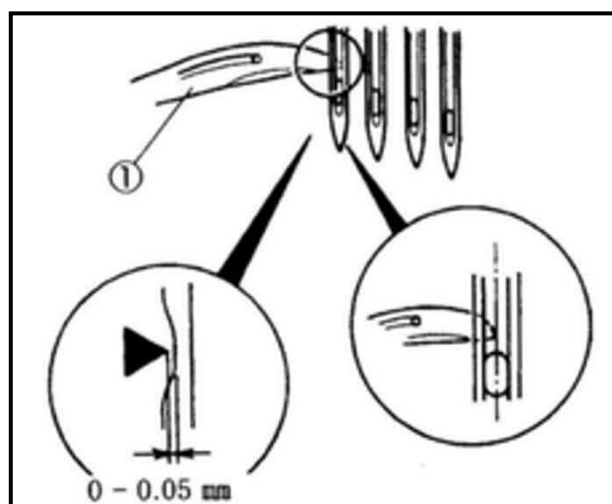

Fig.55

注意：

在调整机器前，一定要先把电源关掉，并确定电机完全停止。

WARNING

Before adjusting, always turn the motor switch OFF and check that the motor has already stopped.

5 · Adjustments 调节装置

5.7 前护针

5.7 Needle guard (front)

当针在左针中间时，推前护针①，使机针和弯针的间隙为 0mm。放松螺钉②去调整。

当弯针左移到右时，检查弯针③有无碰到机针的后面，看机针有无左右移动。(Fig.56,57)

Push the needle guard(front) ① so that the clearance between the needle and the looper is 0 mm when the looper tip comes at the center of the left needle.

Loosen the screw② to adjust it.

Check the looper tip touches the back of the needle and the does not swing to the right when the looper③ moves from the left to the right while rotating the handwheel. (Fig.56,57)

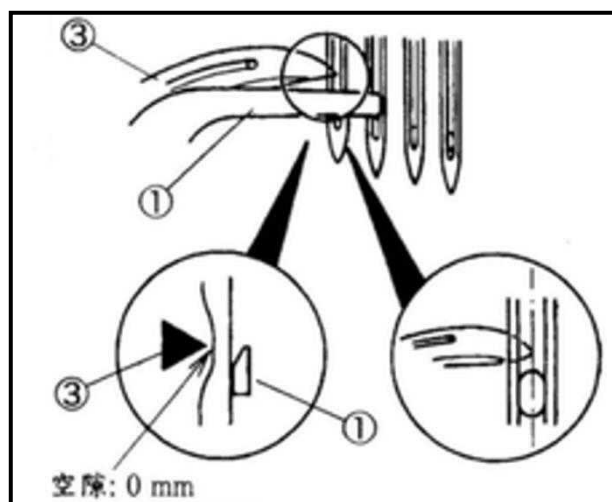

Fig.56

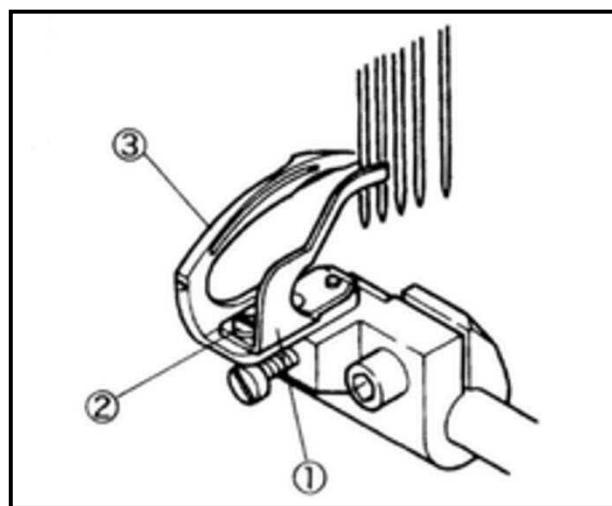

Fig.57

5.8 后护针

5.8 Needle guard(rear)

当后护针④和机针最靠近的时候，要有 0.05-0.1mm 的间隙。由螺钉⑤去调整。(Fig.58)

当弯针从左移动到右时，后护针不能碰到机针。

Make the standard clearance between the needle guard (rear) ④ and the left needle to 0.05-0.1 mm when they meet most closely. Open the looper cover and loosen the screw⑤ to adjust it. (Fig.58)

Check the needle does not swing to the right while rotating the handwheel.

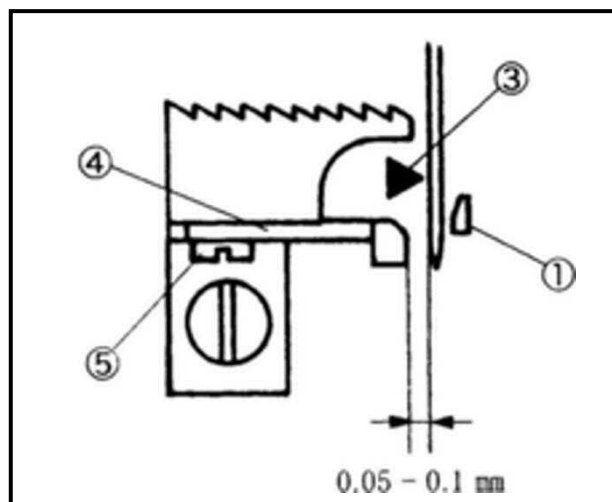

Fig.58

5 · Adjustments 调节装置

注意：

当有调整针距时，注意后护针要重新调整。

CAUTION

After changing stitch length, the clearance changes between the needle guard(rear) set on the main feed doh and the needle.

Readjust the position of the needle guard(rear) after changing stitch length.

注意：

在调整机器前，一定要先把电源关掉，并确定电机完全停止。

WARNING

Before adjusting, always turn the motor stitch OFF and check that the motor has already stopped.

5.9 牙齿高度

5.9 Height of feed dog

安装：

固定差动牙齿和主送牙齿③用螺钉②和④固定后，护针⑤在主送齿上调整时，松开螺钉⑥。(Fig.59)

Fixing：

Fix the differential feed dog① and main feed dog③ with the screw② and④ respectively.

Fix the needle guard(rear)⑤ on the main feed dog and tighten it at the most rear position with the screw⑥ slightly. (Fig.59)

高度：

当牙齿在最高点时，主送齿③和针板高度为 1.2-1.5mm，前后牙齿必须保证一样的高度。(Fig.60)

Height：

Adjust the height from the top of the stitch plate to the part A of the main feed dog③ to 1.2-1.5 mm when the feed dog is at the highest point.

Align the differential feed dog even with the main feed dog. (Fig.60)

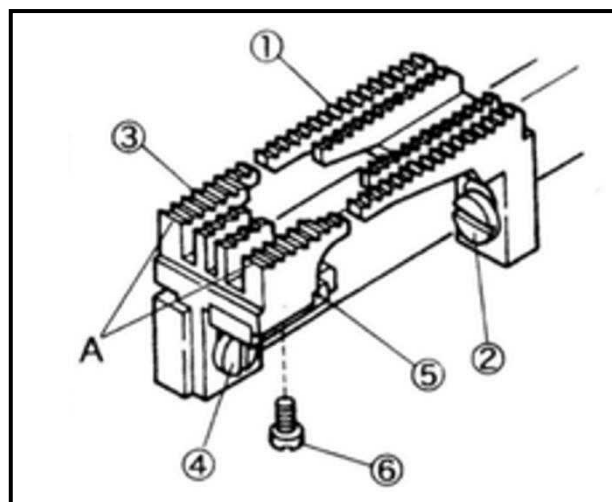

Fig.59

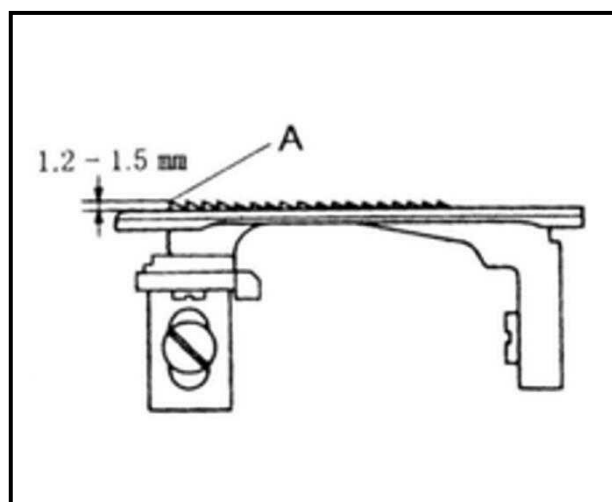

Fig.60

5 · Adjustments 调节装置

高度微调：

牙齿高度微调要旋转偏心销⑧来控制。(Fig.65)松开螺钉⑦然后调整偏心销⑧的高低。

★ 顺时针旋转偏心销⑧降低牙齿。

★ 逆时针旋转偏心销⑧调高牙齿。

Fine adjustment of height :

Make fine adjustment of height of the main and differential feed dogs with the feed bar eccentric pin⑧ near the center of the cylinder.

Loosen the screw⑦ and move the pin⑧ to adjust it.

- To lower the feed dog, turn the pin⑧ clockwise.
- To raise the feed dog, turn the pin⑧ counterclockwise.

注意：

在调整机器前，一定要先把电源关掉，并确定电机完全停止。

WARNING

Before adjusting, always turn the motor switch OFF and check that the motor has already stopped.

5.10 置换压脚

5.10 Replacing presser foot

5.10.1 拆除方法

- 1 移开所有的机针和油塞①。
- 2 松开调整螺母②然后松开螺钉③。
- 3 松开刀台螺钉④让整组刀架松开。
- 4 松开刀座连杆⑥的两颗螺钉⑦，移除上刀座⑤和上刀。
- 5 放松压脚螺钉⑧。
- 6 将针转到最高点，然后移除调整螺母②和抽出压脚轴⑨和压脚弹簧⑩。
- 7 推开喂针驱动片⑪从带动杆⑫脱离。
- 8 向左转，拆下整组压脚穿过左边压脚挡。

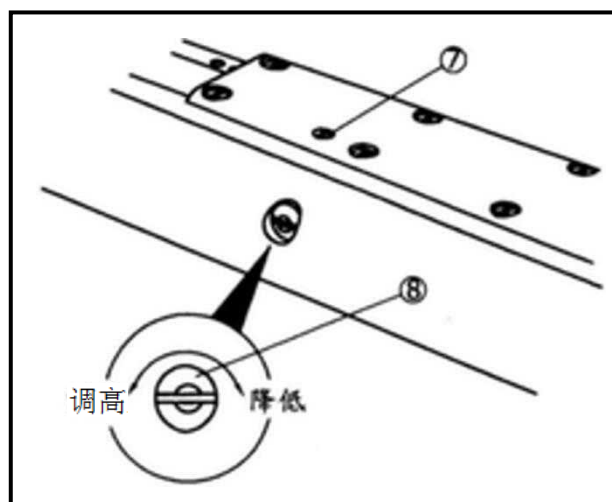

Fig.61

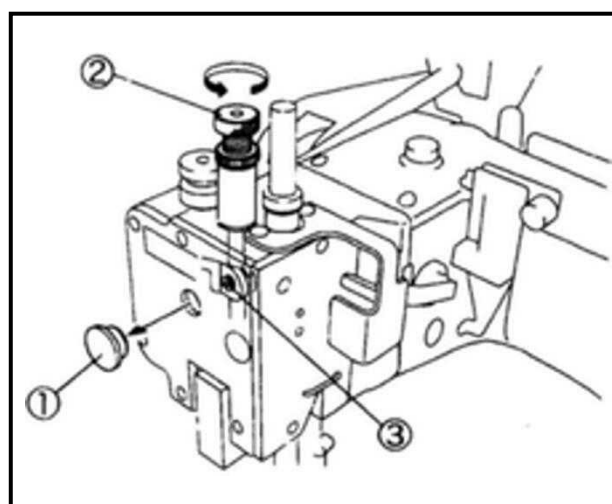

Fig.62

5 · Adjustments 调节装置

5.10.1 Removing :

- (1) Remove all needles and the seal plug ①.
- (2) Loosen the adjusting screw ② and then the screw ③ of the presser bar connecting bracket.
- (3) Loosen the screws ④ of the knife holder guide collar to be free the complete set including the upper knife, the knife holder, and the knife holder shank.
- (4) Loosen two screws ⑦ of the knife holder bracket ⑥ to remove the knife holder guide collar, c.set ⑤ and the upper knife.
- (5) Loosen the screw ⑧ on the back of the presser Foot.
- (6) Rotate the handwheel to raise the needle at the highest point. Remove the adjusting screw ② and keep the presser bar ⑨ and the presser spring ⑩ upward as they come off from the presser foot.
- (7) Remove the carrier/hook driving segment ⑪ from the lever ⑫ on the carrier/hook driving sleeve.
- (8) Turn the presser foot, c.set to the left and remove it through the presser foot guides(left)and(right).

注意：

在调整机器前，一定要先把电源关掉，并确定电机完全停止。

WARNING

Before adjusting, always turn the motor stitch OFF and check that the motor has already stopped.

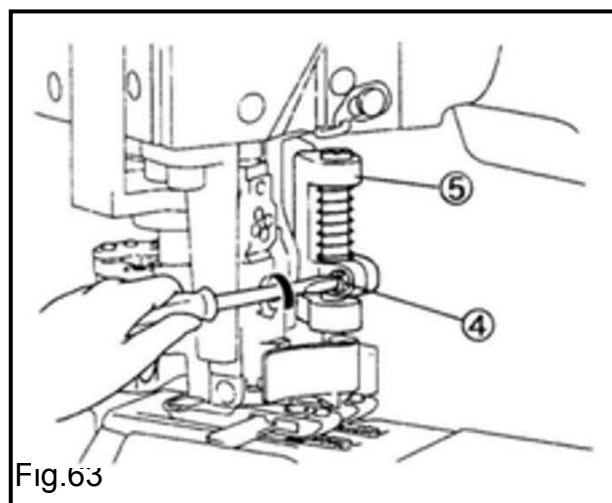

Fig.63

Fig.63

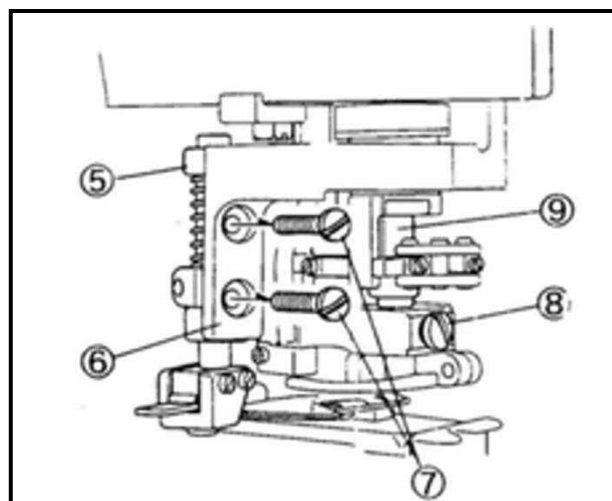

Fig.64

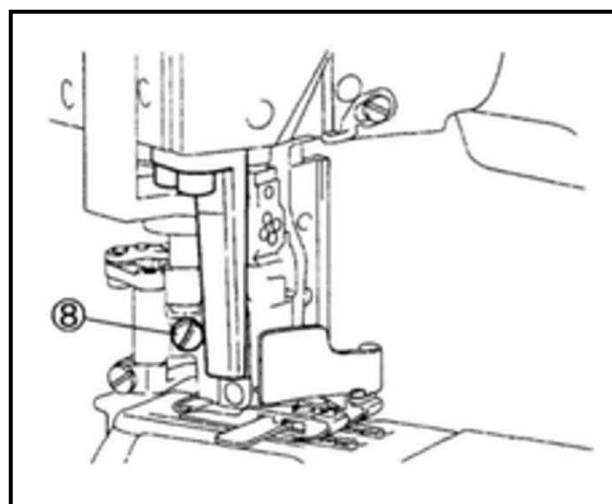

Fig.65

5 · Adjustments 调节装置

5.10.2 组装方法

- (1) 拆掉全部的针重新装上压脚在左右压脚档之间，向右旋转，方正压脚。
- (2) 重新装上喂针驱动片⑪到带动杆⑫里面。
- (3) 安装压脚柱插入喂针驱动片⑪锁紧上压脚后面的螺钉⑧。
- (4) 检查压脚是否顺畅没有左右晃动，如果有卡住，松开左压脚挡⑬的螺钉⑭去调整。
- (5) 重新装上刀台⑤固定在刀座⑥支撑架上。
- (6) 调整刀台与上刀的位置，当机针在最低点时。
- (7) 当压脚紧贴在机针上且机针在最低点时，重新装上刀。压脚簧⑩及调整螺母②，然后锁紧螺钉③。
- (8) 装回油塞①。
- (9) 装回所有机针。

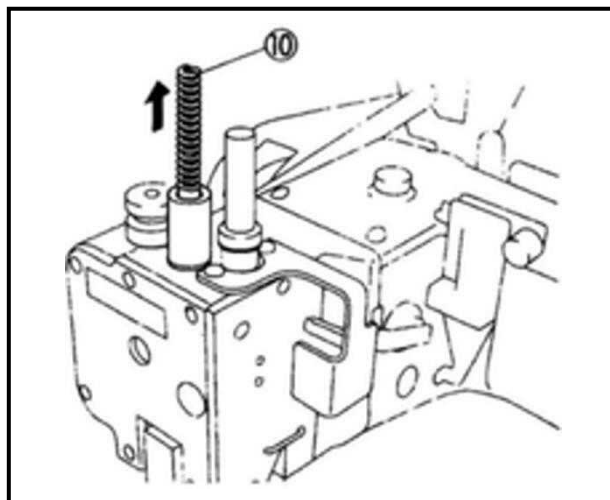

Fig.66

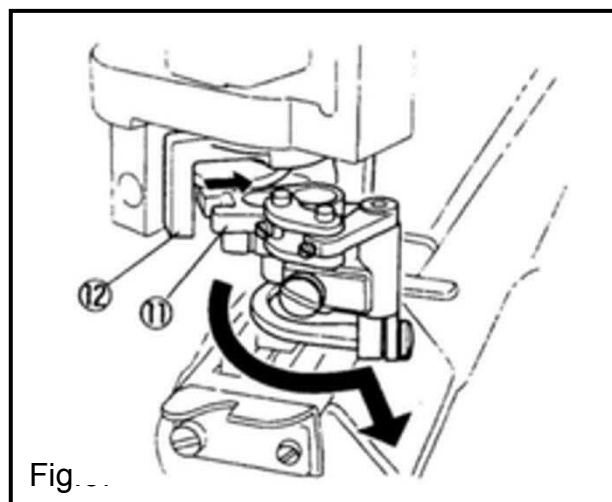

Fig.67

5.10.2 Reseting :

- (1) Remove all needles, Reset the presser foot, c.set between the presser foot guides(left)and (right) while turning ti to the right diagonally from the back.
- (2) Reset the carrier/hook driving segment⑪on the lever⑫on the carrier/hook driving sleeve.
- (3) Insert the presser bar into the carrier/hook driving segment⑪and tighten the screw on the back of the presser foot.
- (4) Check the presser foot moves smoothly without play right and left. If not, loosen the screw⑭of the presser foot guide(left) ⑬to adjust it.
- (5) Reset the knife holder guide collar,c.set⑤and the upper knife on the knife holder bracket⑥ with two screws.
- (6) Adjust the positions of the knife holder guide collar and the upper knife when the needle is at the lowest point.

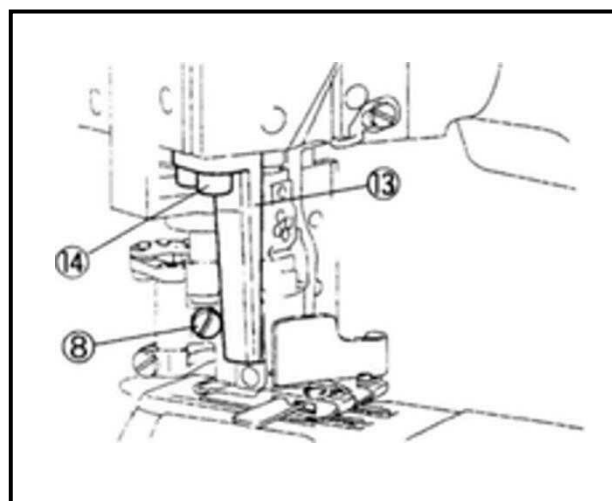

Fig.68

5 · Adjustments 调节装置

- (7) Reset the adjusting screw ② when the needle is at the lowest point and the presser foot touches closely on the stitch plate. Then tighten the screw ③ of the presser bar connecting bracket while pushing slightly down.
- (8) Reset the seal plug ①.
- (9) Reset all needles.

注意：

在调整机器前，一定要先把电源关掉，并确定电机完全停止。

WARNING

Before adjusting, always turn the motor stitch OFF and check that the motor has already stopped.

5.11 置换压脚弹簧片

5.11 Replacing presser foot spring plate

5.11.1 拆除方法

- (1) 拆掉螺钉 ①。
- (2) 拆掉压脚弹簧片 ②。
- (3) 移开弹簧片勾 ③ 才能拿掉弹簧片 ②。

5.11.1 Removing:

- (1) Remove the screw ①.
- (2) Remove the presser foot spring plates ② from the presser foot.
- (3) Remove each plate ② from the spring plate holder ③.

5.11.2 组装方法

- (1) 重新装上压脚弹片 ② 和压脚弹片勾 ③。
- (2) 每片弹簧片 ② 要对着压脚座。
- (3) 锁上螺钉 ①。

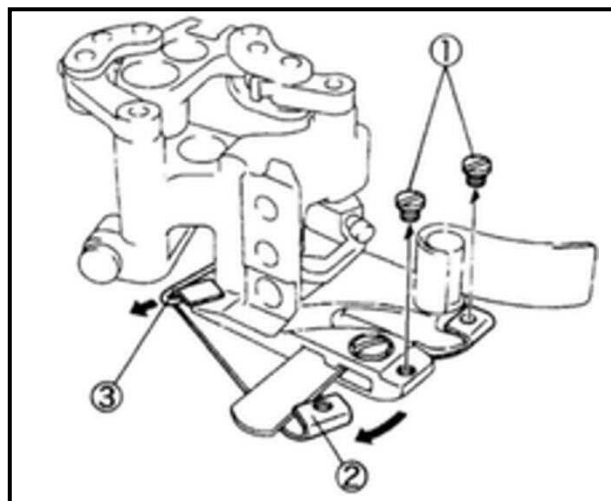

Fig.69

5 · Adjustments 调节装置

5.11.2 Reseting :

- (1) Reset each presser foot spring plate ② with the spring plate holder ③.
- (2) Reset the plates ② parallel each other on the presser foot ②.
- (3) Tighten the screws ① securely.

注意：

在调整机器前，一定要先把电源关掉，并确定电机完全停止。

WARNING

Before adjusting, always turn the motor switch OFF and check that the motor has already stopped.

5.12 置换和调整位置

5.12 Replacing and adjusting knives

5.12.1 上切刀压力

- (1) 当针在最高点，上切刀在左边时压脚要贴着针板，上切刀 ① 刀刃要切合下切刀 ② 的刀刃。
- (2) 刀座 ③ 和压力弹簧轴环 ④ 之间的标准间隙为 1.0 mm。
- (3) 松开螺钉 ⑤ 和移动轴环 ④ 调整压力。

- ★ 增加压力往上移动弹簧轴环 ④。
- ★ 减小压力往下移动弹簧轴环 ④。

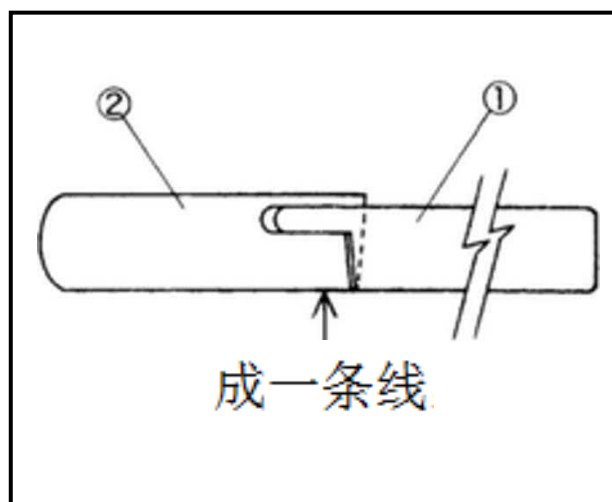

Fig.70

5.12.1 Pressure of upper knife:

- (1) When the needle is at the highest point and the upper knife ① is at the extreme left, the presser foot touches the stitch plate, and the upper knife ① touches the lower knife ② closely.
- (2) The standard clearance between the bearing of the knife holder shank support ③ and the knife holder guide collar ④ is 1.0 mm.
- (3) Loosen the screw ⑤ and move the knife holder guide collar ④ to adjust the pressure.

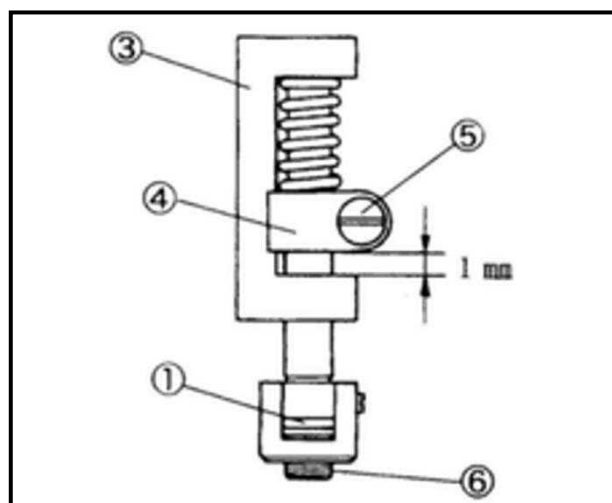

Fig.71

- To increase the pressure, move the collar ④ upward.
- To decrease the pressure, move the collar ④ downward.

5 · Adjustments 调节装置

注：上刀①和下刀②成一条线，上刀不能碰到压脚壁，正确后固定弹簧轴环。

Note: Align the front sides of the upper ① and lower ② knives without touching the upper knife to the presser foot. After check them, fix the knife holder guide collar ④ with the screw.

5.12.2 拆除方法

- (1) 放松螺钉⑤和⑥才能拆掉上切刀①。
- (2) 放松螺钉⑦才能拆掉下切刀②。

5.12.2 Removing :

- (1) Loosen the screws ⑤ and ⑥ to remove the upper knife ①.
- (2) Loosen the screw ⑦ to remove the lower knife ②.

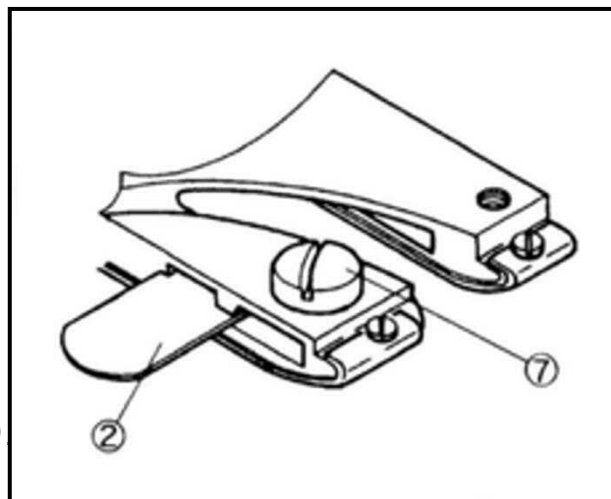

Fig.72

5.12.3 组装方法

- (1) 重新安装下切刀②要锁紧螺钉⑦。
- (2) 重新安装上切刀①要锁紧螺钉⑥。

5.12.3 Resetting :

- (1) Reset the lower knife ② with the screw ⑦.
 - (2) Reset the upper knife ① with the screw ⑥.
- See “5.9 Adjusting lapped width of upper fabric” for engagement of the knives.

5.12.4 上切刀角度调整

- (1) 拆掉①-⑤的部份，通过螺钉⑥去调整刀的角度。
- (2) 重新安装时注意销⑦有无对准刀座⑧上的孔。

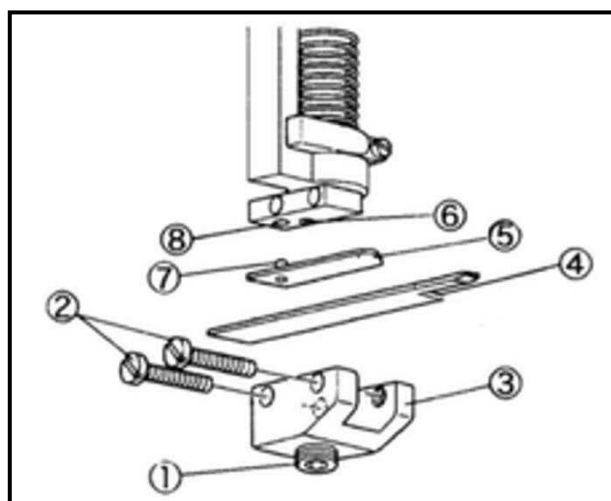

Fig.73

5.12.4 Engaging angle of upper knife to lower knife

- (1) Remove the parts ①-⑤ in the order and turn the screw ⑥ to adjust it.
- (2) When resetting, check the screw ⑦ is not out from the bottom of the knife support ⑤. Then insert it into the bracket hole ⑧ to tighten.

机型	JK-8740
说明	曲臂型四针六线拼缝机
规格	长 420mm x 宽 300mm x 高 410mm
圆周	针杆下边最小圆周 148mm
工作空间	圆周 210mm
重量	23 公斤 (头部)
车缝速度	最高 3200 R.P.M. ; 普通 2700 R.P.M.
针距	1.6-2.5mm 每英寸 10-16 针 ; 每 30mm 12-19 针
针型号	车针 : Organ FLX118GCS ; Groz-Beckert UY118GKS 假针 : Organ FLG-1 , FLF-8 ; Groz-Beckert 36211 , 36211A
针距	R : 5.2mm S : 6.0mm
抬压脚	01 (单切) : 最大 8mm 02 (双切) : 最大 6mm
差动比	一般差动比 : 1.0 : 1.5 反差动比 : 1.0 : 0.7
切布刀	特殊钢材制造
润滑	齿轮泵润滑
润滑油	TELLUS 46
油槽容量	框 : 约 100cc 筒 : 约 100cc

CONTENTS	目录	部件号
MISCELLANEOUS COVERS (1)	机壳部件1	1
MISCELLANEOUS COVERS (2) LC62D LC62DU	机壳部件2	2
MISCELLANEOUS THREAD EYELETS	过线部件	3
MISCELLANEOUS BUSINGS	套筒部件	4
MAIN SHAFT DEIVING MECHANISM	上轴与针杆部件	5
PRESSER FOOT MECHANISM	压布部件	6
UPPER KNIFE CARRIER AND HOOK DRIVING MECHANISM	上切刀及喂针部件	7
LOOPER DEIVING MECHANISM	弯针部件	8
FEED DEIVING MECHANISM LC62D LC62DU	送料部件1	9
FEED DEIVING CONTROL MECHANISM LC62D LC62DU	送料部件2	10
LUBRICATING MECHANISM	润滑部件	11
12MR EXCLUSIVE PARTS	专用零件	12
/SV/ DEVICE	伺服电机部件	13
/E/ DEVICE	抬压脚电磁铁部件	14
ATTACHMENT	附件	15
THREAD STAND	线架组件	16
/S/ DEVICE	吸布屑组件	17
01 MS EXCLUSIVE PARTS	专用零件	18
12MS EXCLUSIVE PARTS	专用零件	19
12HS EXCLUSIVE PARTS	专用零件	20
12HS EXCLUSIVE PARTS	专用零件	21
01HR. 01HS EXCLUSIVE PARTS	专用零件	22
/A/ DEVICE	气动抬压脚部件	23
/AS/ DEVICE	吸布屑及气动压布组件	24
13MR EXCLUSIVE PARTS (1)	主零件型号区分	25
13MR EXCLUSIVE PARTS (2)	专用零件	26
13MS EXCLUSIVE PARTS (1)	专用零件	27
13MS EXCLUSIVE PARTS (2)	专用零件	28
CLASS LIST OF MAIN SPARE PARTS	主零件型号区分	29

1

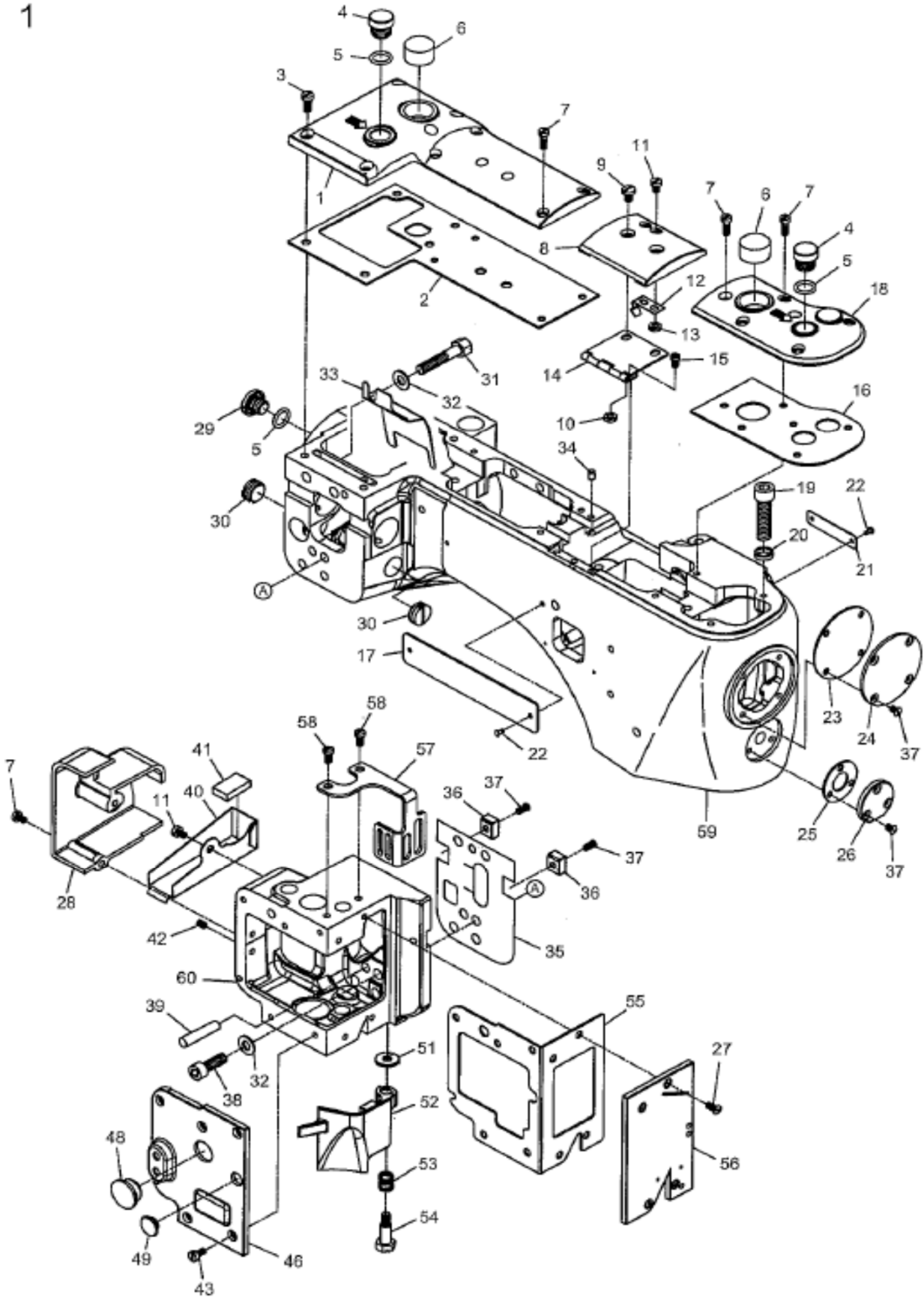

序号 Ref. N	公司件号 Parts. No	名称	Description	数量Number
1	A0101	上盖	Crank Chamber Cover	1
2	A0102	上盖垫	Crank Chamber Cover Gasket	1
3	A0103	螺钉	Screw (11/64-40x10)	5
4	A0104	螺钉	Screw (M12-1.75x9)	2
5	A0105	O型圈	Oring (P10)	3
6	A0106	油窗	Oil Sight Top Window	2
7	A0834	螺钉	Screw (9/64-40x11)	12
8	A0108	打线凸轮盖板	Top Cover (Middle)	1
9	A1009	螺钉	Screw (11/64-40x8)	2
10	A0110	螺母	Nut	2
11	A0111	螺钉	Screw (9/64-40x5.6)	5
12	A0112	打线凸轮盖板止动片	Top Cover (Middle) Spring	1
13	A0113	螺母	Nut	2
14	A0114	打线凸轮盖板活动板	Top Cover (Middle) Hinge	1
15	A0115	螺钉	Screw (9/64-40x6)	3
16	A0116	上盖垫	Top Cover (Front)	1
17	A0117	长标签	Brand Name Sticker	1
18	A0118	上盖(前)	Top Cover (Front) Gasket	1
19	A0119	螺钉	Screw (5/16-24x32)	3
20	A0120	垫片	Washer	3
21	A0121	短标签	Serial Number Plate	1
22	A0122	铆钉	Rivet	4
23	A0123	挡油垫片	Machine Frame End Cover Gasket	1
24	A0124	挡油盖	Machine Frame End Cover	1
25	A0125	挡油垫片	Looper Lever Shaft Cover Gasket	1
26	A0126	挡油盖	Looper Lever Shaft Cover	1
27	A0127	螺钉	Screw (9/64-40x8)	4
28	B01128	车头盖	Sewing Head Cover	1
29	A0129	螺钉	Drain Hole Screw (3/8-24x8)	1
30	A0130	防油螺钉	Plug Screw (M14-1x4.8)	2
31	A0130	螺钉	Screw (1/4-28x32.5)	2
32	A0130	垫片	Washer	2
33	A0130	挡油片	Crank Chamber Cover Oil Shield	1
34	A0130	橡胶塞	Oil Seal Plug	1
35	A0130	防油板	Sewing Head Oil Defense	1
36	A0130	机壳固定块	Sewing Head Key	2
37	A0130	螺钉	Screw (9/64-40x8)	2
38	A0130	螺钉	Screw (1/4-28x20)	1
39	A0130	销	Pin	1
40	A0130	油槽	Knife Driving Connection Oil Guard	1
41	A0130	油棉	Knife Driving Connection Felt	1
42	A0130	螺钉	Screw (9/64-40x6)	2
43	A0130	螺钉	Screw (9/64-40x7.3)	6
44				
45				
46	B0231	车头盖	Sewing Head Cover (Left)	1
47				
48	A0148	油塞	Seal Plug	1
49	A0149	油塞	Seal Plug	1
50				
51	A0166	垫片	Frame Chip Guard Washer	1
52	B1746	防护板	Frame Chip Guard	1
53	A0153	弹簧	Frame Chip Guard Spring	1
54	A0154	螺钉	Screw (M5-0.8X8.7)	1
55	A0155	止油垫片	Sewing Head Cover Gasket	1
56	A0156	车头前盖	Sewing Head Cover Gasket (Front)	1
57	A0157	护盖	Needle Thrad Take-up Guard	1
58	A0158	螺钉	Screw (M4-0.7x7.8)	2
59	A0159	机壳	Machine Frame	1
60	A0160	机壳	Machine Frame	1

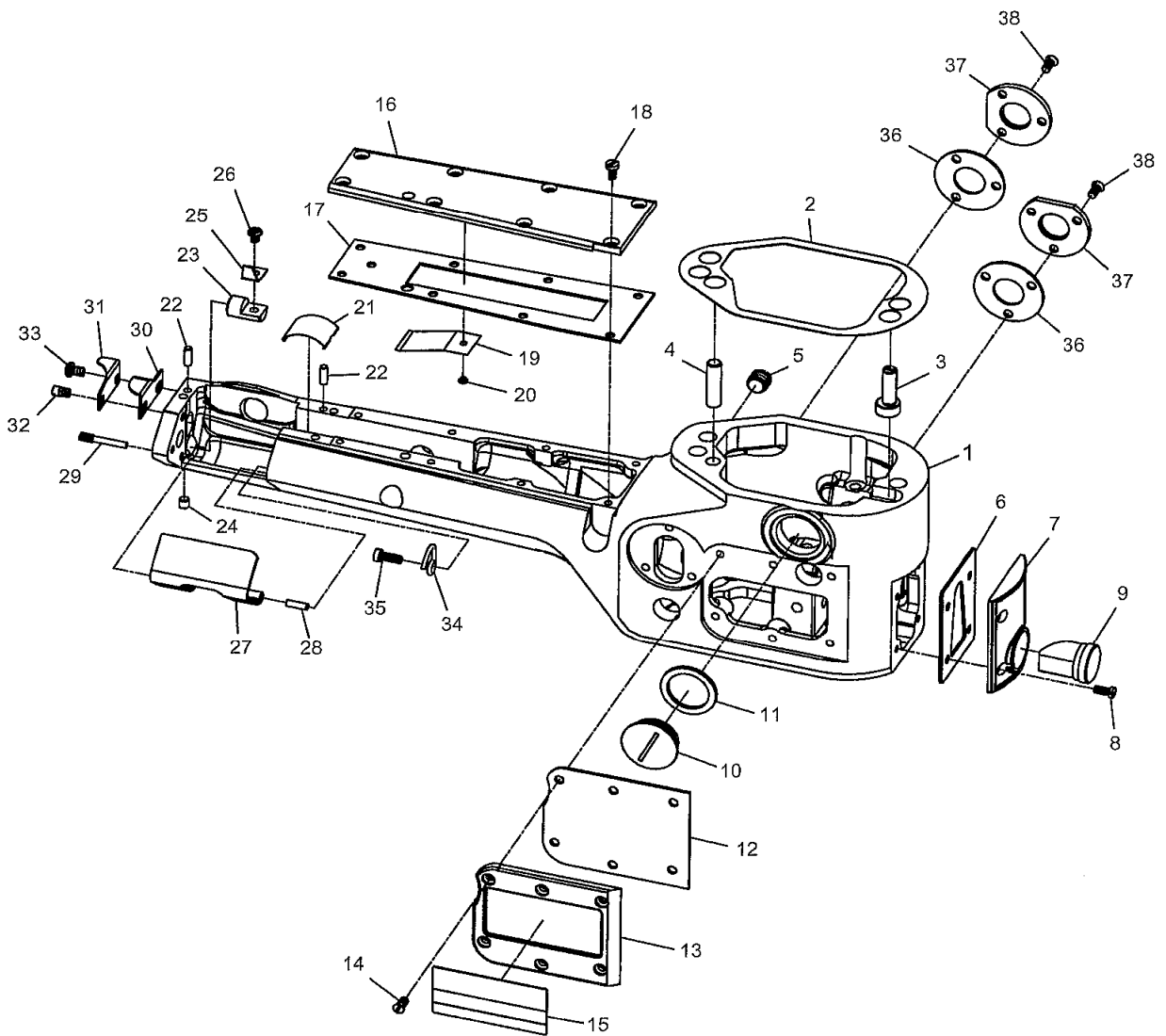

序号 Ref. N	公司件号 Parts. No	名称	Description	数量Number
1	A0201	机壳下节	Sewing Cylinder	1
2	A0202	拼装垫片	Sewing Cylinder Gasket	1
3	A0203	拼装螺钉	Alignment Pin	1
4	A0204	拼装销	Knock Pin	1
5	A0205	螺钉	Screw (3/8-24×5.4)	1
6	A0206	油标盖板垫片	Seal Gasket	1
7	A0207	油标盖板	Cylinder Frame Cover (Front)	1
8	A0208	螺钉	Screw (1/8-44×7.7)	4
9	A0209	油标	Oil Gauge	1
10	A0210	螺钉	Screw (M22-15×5.7)	1
11	A0211	橡胶垫片	Gasket	1
12	A0212	挡油垫片	Seal Gasket	1
13	A0213	左盖	Cylinder Frame Cover (Left)	1
14	A0137	螺钉	Screw (9/64-40×8)	6
15	A0215	型号牌	Model Rate	1
16	A0216	切刀盖	Cylinder Frame Cover (Upper)	1
17	A0217	切刀盖垫	Seal Gasket	1
18	A0218	螺钉	Screw (1/8-44×65)	8
19	A0219	挡油垫上	Dust Defender (Upper)	1
20	A0220	螺钉	Screw (3/32-56×2.1)	1
21	A0221	挡油垫下	Dust Defender (Lower)	1
22	A0222	销	Pin	2
23	A0223	弹簧片座	Looper Cover Spring Support	1
24	A0224	螺钉	Screw (11/64-40×43)	1
25	A0225	弯针盖弹簧片	Looper Cover Spring	1
26	A0226	螺钉	Screw (9/64-40×4.7)	1
27	A0227	弯针盖	Cover	1
28	A0228	销	Pin	1
29	A0229	螺钉	Screw (9/64-40×6.4)	1
30	A0230	割刀	Chairwiff Cutting Knife	1
31	A0231	割刀固定片	Chairwiff Cutting Knife Guard	1
32	A0232	螺钉	Screw (M4-0.7×4)	1
33	A0233	螺钉	Screw (M4-0.7×5.8)	1
34	A0234	过线片	Looper Thread Guide Wire	1
35	A0235	螺钉	Screw (9/64-40×10)	1
36	A0236	挡油垫片	Feed Drive Shaft Cover Gasket	2
37	A0237	挡油盖	Feed Drive Shaft Cover	2
38	A0151	螺钉	Screw (9/84-40×5.6)	6

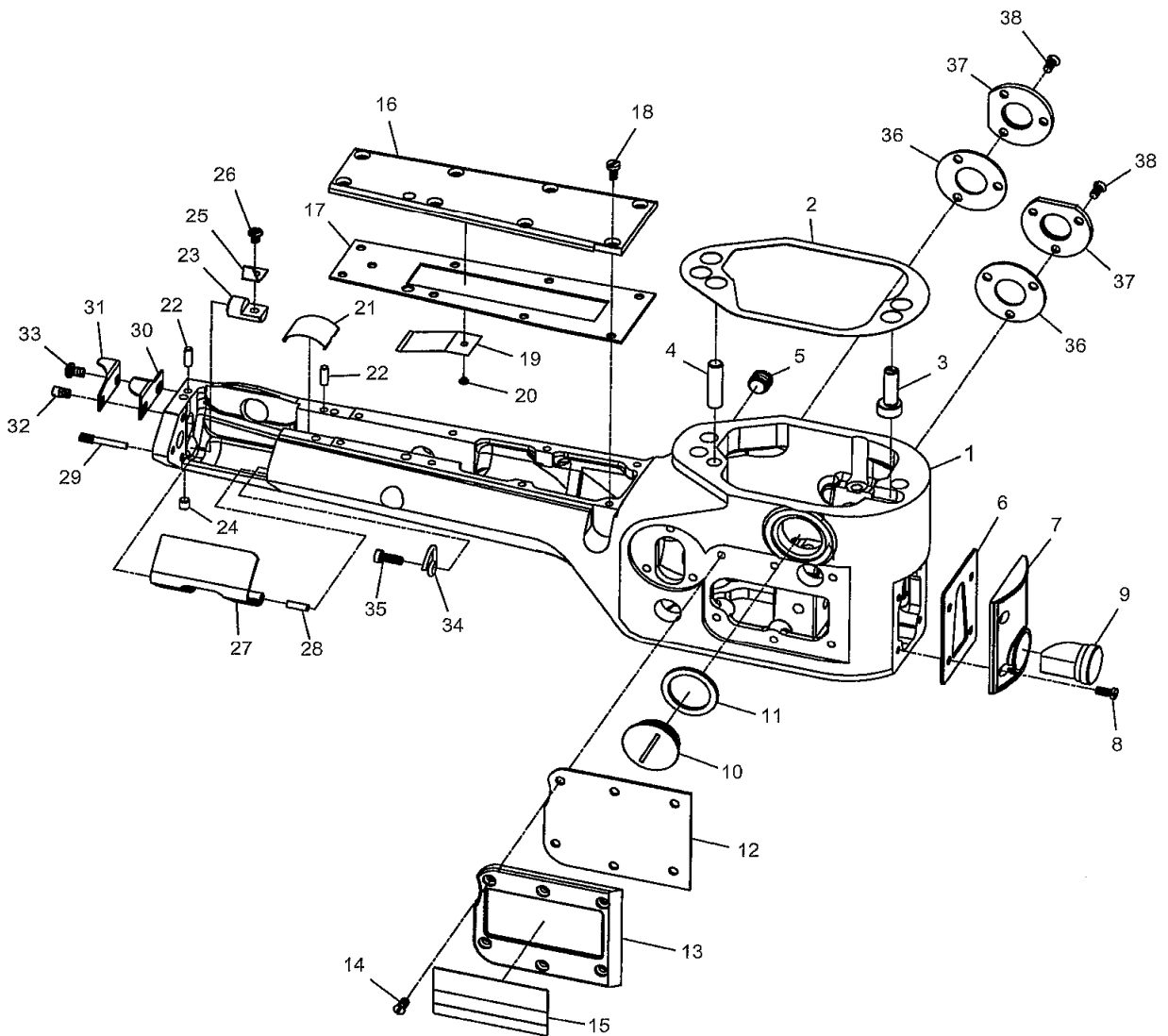

序号 Ref. N	公司件号 Parts. No	名称	Description	数量Number
1	A0201	机壳下节	Sewing Cylinder	1
2	A0202	拼装垫片	Sewing Cylinder Gasket	1
3	A0203	拼装螺钉	Alignment Pin	1
4	A0204	拼装销	Knock Pin	1
5	A0205	螺钉	Screw (3/8-24×5.4)	1
6	A0206	油标盖板垫片	Seal Gasket	1
7	A0207	油标盖板	Cylinder Frame Cover (Front)	1
8	A0208	螺钉	Screw (1/8-44×7.7)	4
9	A0209	油标	Oil Gauge	1
10	A0210	螺钉	Screw (M22-15×5.7)	1
11	A0211	橡胶垫片	Gasket	1
12	A0212	挡油垫片	Seal Gasket	1
13	A0213	左盖	Cylinder Frame Cover (Left)	1
14	A0137	螺钉	Screw (9/64-40×8)	6
15	B02015	型号牌	Model Rate	1
16	A0216	切刀盖	Cylinder Frame Cover (Upper)	1
17	A0217	切刀盖垫	Seal Gasket	1
18	A0218	螺钉	Screw (1/8-44×65)	8
19	A0219	挡油垫上	Dust Defender (Upper)	1
20	A0220	螺钉	Screw (3/32-56×2.1)	1
21	A0221	挡油垫下	Dust Defender (Lower)	1
22	A0222	销	Pin	2
23	A0223	弹簧片座	Looper Cover Spring Support	1
24	A0224	螺钉	Screw (11/64-40×43)	1
25	A0225	弯针盖弹簧片	Looper Cover Spring	1
28	A0226	螺钉	Screw (9/64-40×4.7)	1
27	A0227	弯针盖	Cover	1
28	A0228	销	Pin	1
29	A0229	螺钉	Screw (9/64-40×6.4)	1
30	A0230	割刀	Chairwiff Cutting Knife	1
31	A0231	割刀固定片	Chairwiff Cutting Knife Guard	1
32	A0232	螺钉	Screw (M4-0.7×4)	1
33	A0233	螺钉	Screw (M4-0.7×5.8)	1
34	A0234	过线片	Looper Thread Guide Wire	1
35	A0143	螺钉	Screw (9/64-40×10)	1
36	A0236	挡油垫片	Feed Drive Shaft Cover Gasket	2
37	A0237	挡油盖	Feed Drive Shaft Cover	2
38	A0151	螺钉	Screw (9/84-40×5.6)	6
39	B02039	切刀盖组件	Cylinder Frame Cover (Upper), C. Set	1
40	B02040	O型圈	O ring	1
41	B02041	螺钉	Screw (3/16-32x6)	1

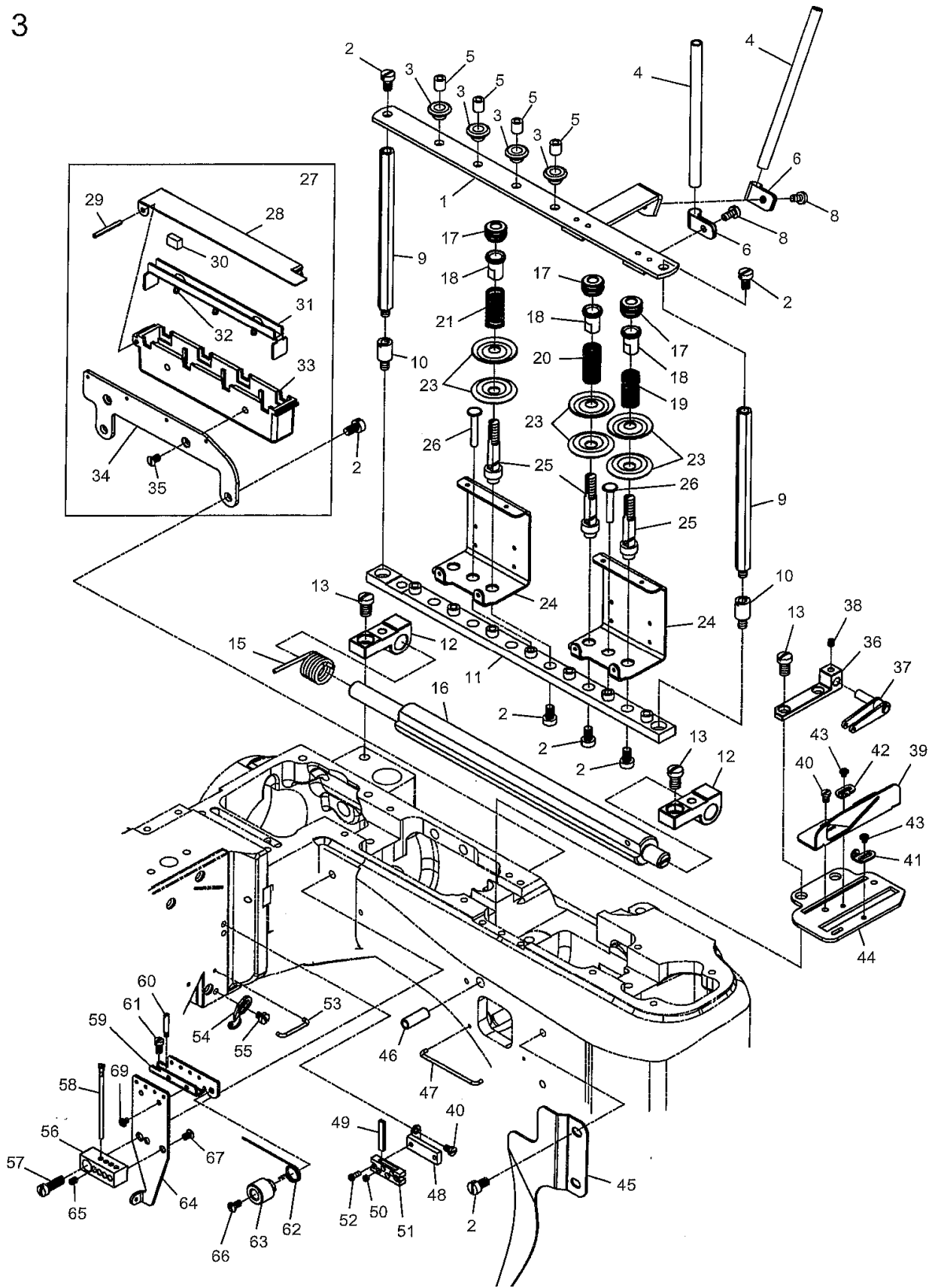

序号 Ref. N	公司件号 Parts. No	名称	Description	数量 Number
1	B0401	线架板	Thread Guide Plate	1
2	A1009	螺钉	Screw (11/64-40x7.7)	12
3	B0403	过线孔套	Thread Eyelet Bushing	4
4	A0304	过线管(长)	Thread Pipe (Long)	2
5	B0404	过线孔	Thread Eyelet	4
6	B0406	线夹	Thread Pipe Stay	2
7				
8	A0143	螺钉	Screw (9/64-40x7.3)	2
9	A0309	线架板支撑棒	Thread Guide Plate Support	2
10	A0310	螺钉	Screw (11/64-40x7)	2
11	A0311	夹线器固定座	Thread Tension Support	1
12	A0312	夹线器固定座支架	Thread Tension Support Bracket	2
13	A0313	螺钉	Screw (7/32t32x9.3)	4
14				
15	A0315	扭簧	Tension Release Shaft Spring	1
16	B0416	松线轴	Tension Release Shaft	1
17	A0317	夹线器止动盖	Nut	6
18	A0318	夹线器止动螺母	Tension Spring Bushing	6
19	A0319	夹线器弯针弹簧	Looper Thread Tension Spring	1
20	A0320	夹线器喂针弹簧	Top Cover Thread Tension Spring	1
21	A0321	夹线器机针弹簧	Needle Thread Tension Spring	4
22				
23	A0323	夹线片	Thread Tension Disc	12
24	A0324	夹线器过线架	Thread Tension Disc Eyelet	3
25	A0325	夹线器螺钉	Tension Post (Short)	6
26	A0326	销	Tension Release Pin	7
27	A0327	针线吸油组件	SPDevice, C. Set	1
28	A0328	硅油储存盒盖	Oil Cup Lip	1
29	A0329	销	Hinge Pin	1
30	A0330	油棉	SP Felt	4
31	A0331	油棉架	SP Felt Stay	1
32	A0332	油线	Oil Wick	1
33	A0333	硅油储存盒	SP Container	1
34	A0334	硅油储存盒固定座	SP Container Support	1
35	A0151	螺钉	Screw (9/64-40x5.6)	2
36	A0336	打线杆支架	Thread Take-up Eyelet Holder	1
37	A0337	打线杆	Thread Take-up Eyelet	1
38	A0338	螺钉	Screw (1/8-44x4)	5
39	A0339	打线片	Looper Thread Take-up Guide	1
40	A0340	螺钉	Screw (1/8-44x4.5)	4
41	A0341	过线片(前)	Looper Thread Take-up Eyelet (Front)	1
42	A0342	过线片(后)	Looper Thread Take-up Eyelet (Rear)	1
43	A0343	螺钉	Screw (3/32-56x3)	4
44	A0344	打线架	Eyelet Supporting Plate	1
45	A0345	弯针过线导架	Looper Thread Guard	1
46	A0346	喂针过线过线导管	Top Cover Thread Pipe	1
47	A0347	弯针过线导架固定杆	Looper Thread Guide Wire (Upper)	1
48	B0448	弯针过线导架固定板	Needle Thread Strike-off Pin Holder Plat	1
49	A0349	过线导架调整片	Needle Thread Strike-off Pin	4
50	A0350	螺钉	Screw (1/8-44x2)	4
51	B0451	过线导架固定架	Needle Thread Strike-off Pin Holder Brac	1
52	B0452	螺钉	Screw (3/32-56x5.7)	2
53	A0353	机针过线导架固定杆	Needle Thread Guide Wire	1
54	A0354	喂针过线过线片	Head Cover Thread Eyelet	1
55	A0355	螺钉	Screw (1/8-44x4)	1
56	A0356	过线座	Needle Thread Eyelet Holder	1
57	A0357	螺钉	Screw (11/64-40x13)	1
58	A0358	过线杆	Needle Thread Eyelet	4
59	A0359	挑线弹簧支架	Stitch Unlocker Mounting Bracket	1
60	A0360	螺钉	Screw (3/32-56x3)	1
61	A0361	螺钉	Screw (1/8-44x6.4)	1
62	A0362	挑线弹簧	Stitch Unlocking Spring	1
63	A0363	挑线弹簧调整固定套	Stitch Unlocking Spring Holder	1

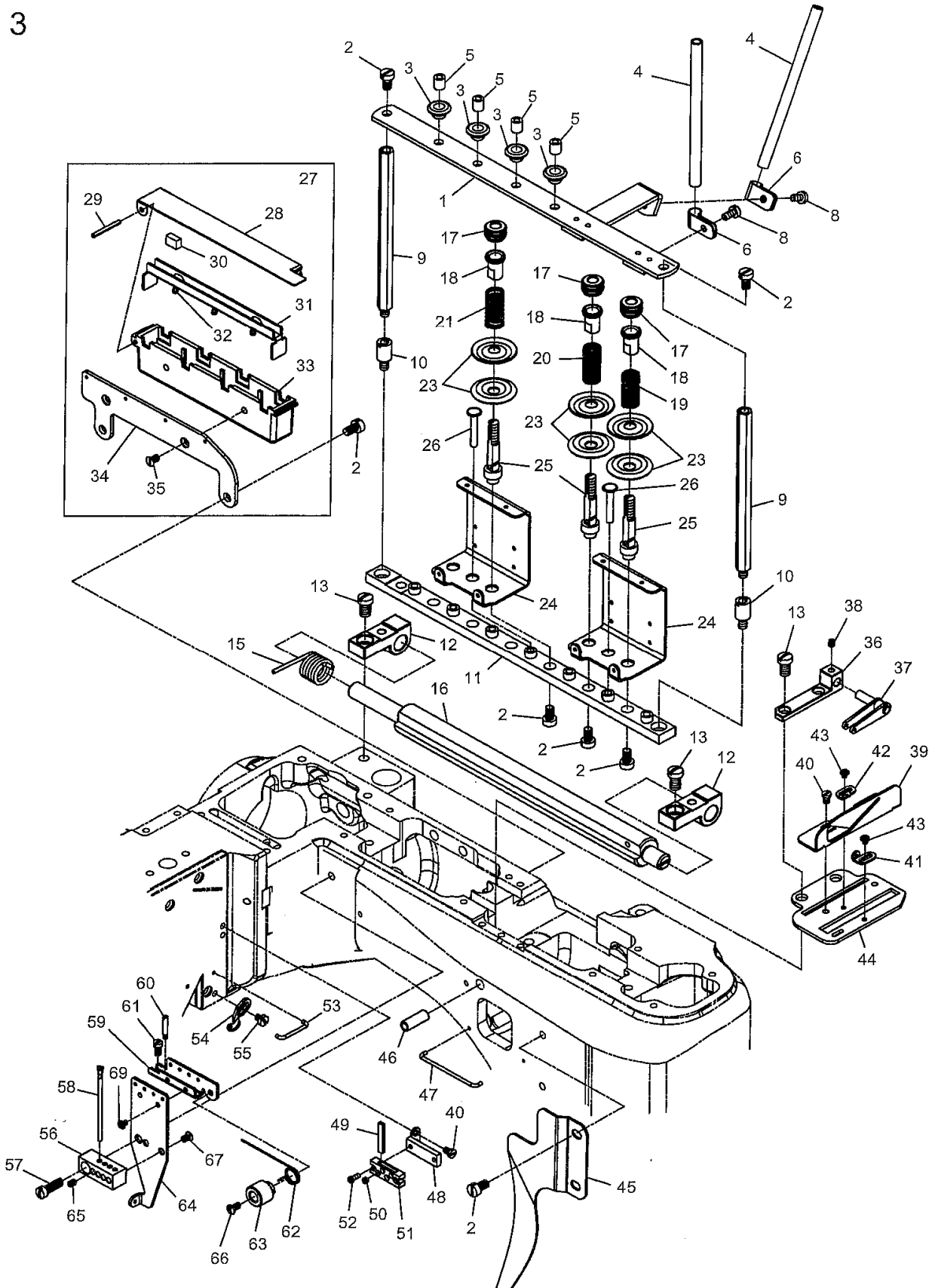

64	A0364	过线支撑架	Needle Bracket	1
65	A0365	过线调整片架组	Needle Thread Strike-off Pin Holder, C.	1
66	A0366	螺钉	Screw (1/8-44x5.4)	1
67	A0367	螺钉	Screw (1/8-44x4.4)	2

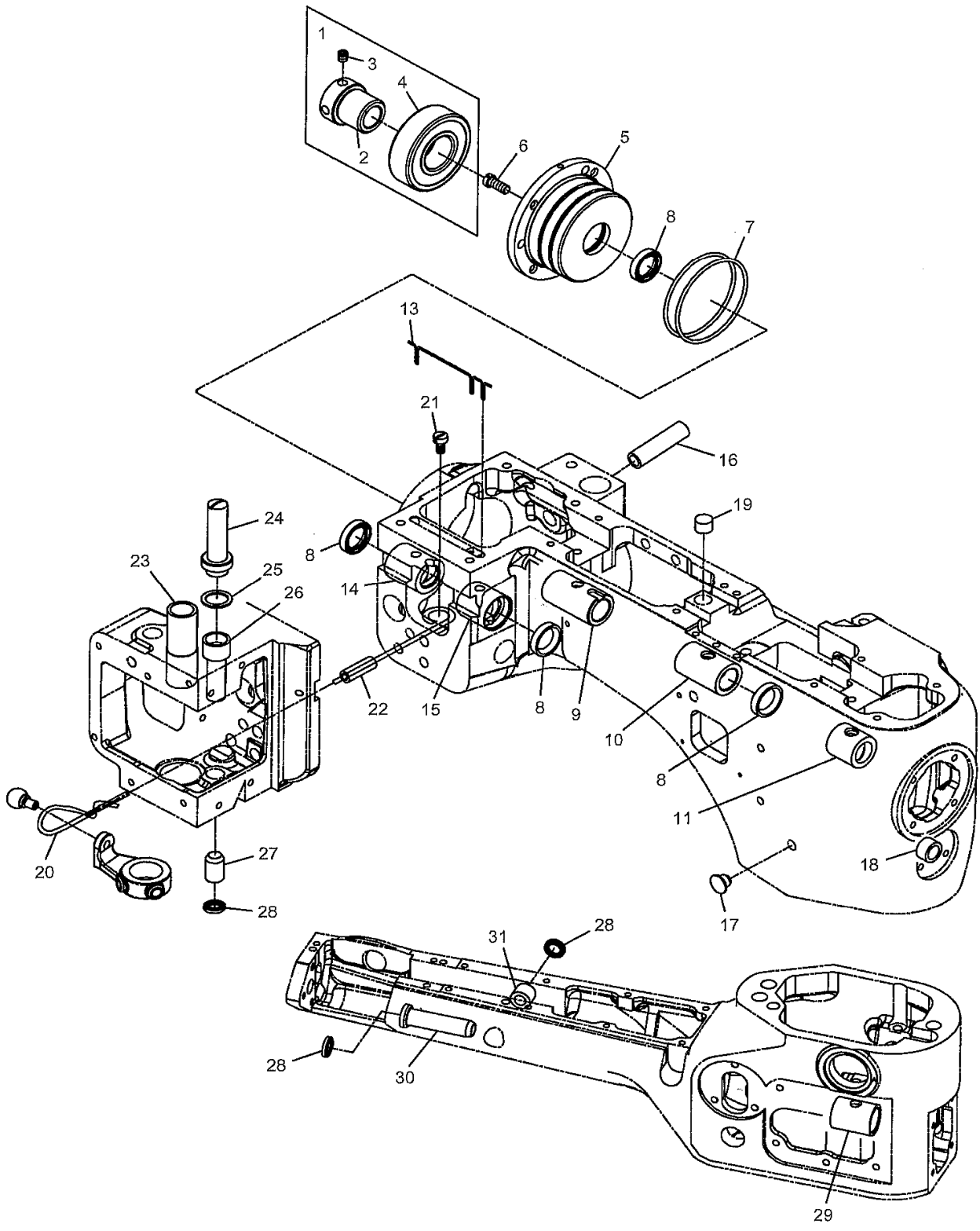

序号 Ref. N	公司件号 Parts. No	名称	Description	数量 Number
1	A0401	轴承组件	Adapter, C. Set	1
2	A0402	轴承套	Adapter	1
3	A0403	螺钉	Screw (M5-0.8x5)	2
4	C06006	轴承	Ball Bearing	1
5	A0405	轴程挡圈	Bearing Housing	1
6	A0406	螺钉	汹毗3/[6-32x11.8)	4
7	B0507	O型圈	O-Ring	2
8	B0508	油封	Oil Seal	4
9	B04109	主轴套(后)	Main Shaft Bushing(Rear)	1
10	B04110	主轴套(中)	Main Shaft Bushing(Middle)	1
11	A0411	主轴套(前)	Main Shaft Bushing(Front))	1
12				
13	A0413	油线	Oil Wick(Laced Wire))	1
14	A0414	铜套(后)	Knife Driving Lever Bushing(Rear)	1
15	A0415	铜套(前)	Knife Driving Lever Bushing(Front)	1
16	A0416	衬套	Presser Foot Lifter Stop Plunger Bushing	1
17	A0417	油塞	Seal Plug	1
18	A0418	衬套	Bushing	1
19	A0419	油塞	Plug	1
20	A0420	油线	Oil Wick	1
21	A1009	螺钉	Screw (11/64-40x8)	1
22	A0422	油管	Plastic Pipe	1
23	A0423	压脚轴套	Presser Bar Bushing	1
24	A0424	针杆盖	Needle Bar Bushing(Upper)Lid	1
25	A0425	垫片	Gasket	1
26	A0426	针杆套(上)	Needle Bar Bushing(Upper)	1
27	A0427	针杆套(下)	Needle Bar Bushing(Lower)	1
28	A0428	油封	Oil Seal	3
29	A0429	下弯针摆动杆轴套(前)	Looper Rocker Shaft Bushing(Front)	1
30	A0430	下弯针摆动杆轴套(后)	Looper Rocker Shaft Bushing(Rear)	1
31	A0432	送料偏心销套	Feed Bar Eccentric Pin Bushing	1

5

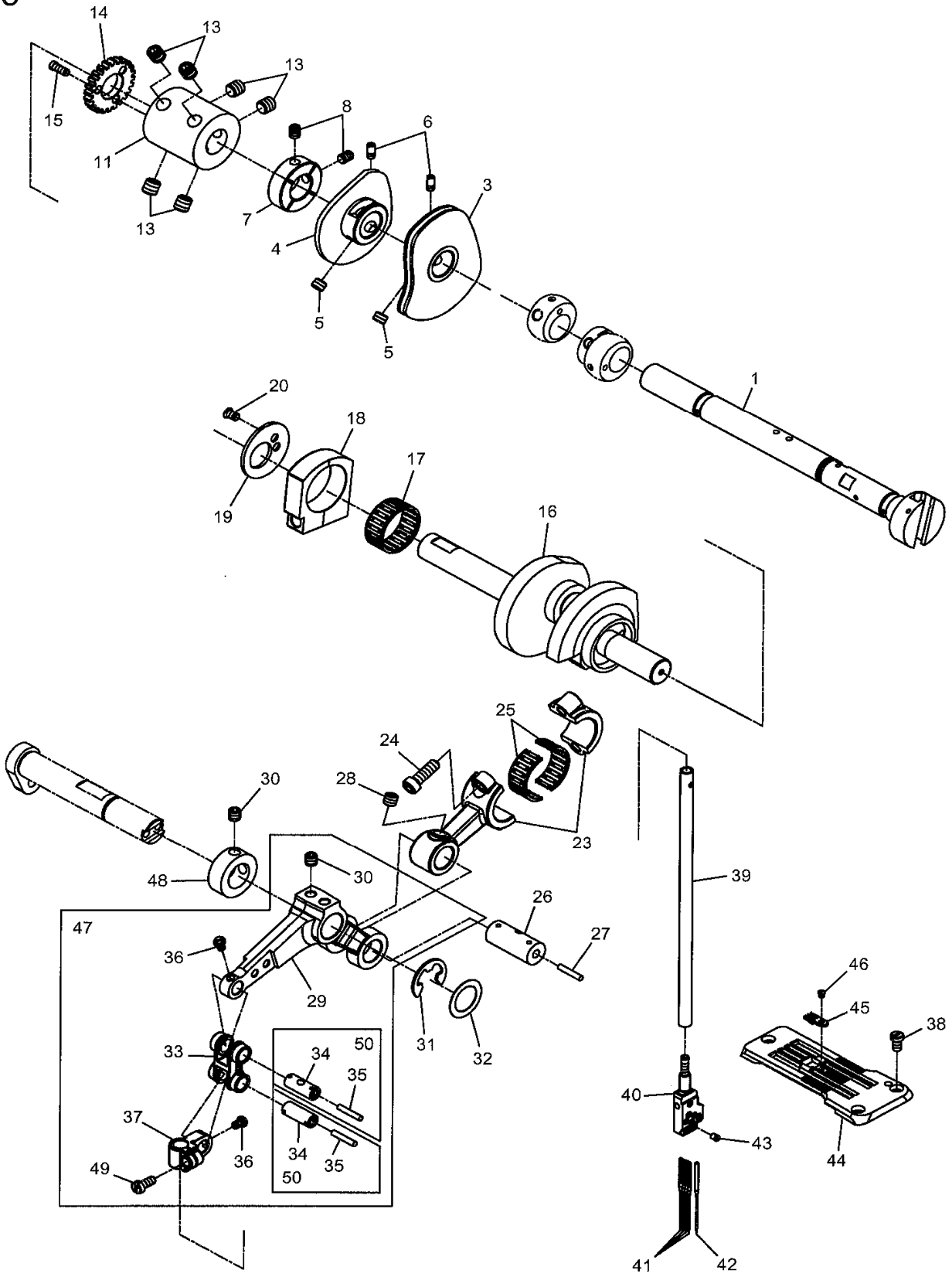

序号 Ref. N	公司件号 Parts. No	名称	Description	数量 Number
1	A0501	主轴	Main Shaft Coupling	1
3	A0503	弯针线打线凸轮	Looper Thread Take-Up	1
4	A0504	喂针线打线凸轮	Top Cover Thread Take-Up	1
5	A0505	螺钉	Screw (7/32-32x3.6)	4
6	A0506	螺钉	Screw (1/8-44x5.3)	2
7	A0507	轴套	Collar	2
8	A0508	螺钉	Screw (11/64-40x5.8)	4
10				
11	A0511	主轴连接套	Main Shaft Coupling	1
12				
13	A0513	螺钉	Screw (1/4-28x6.4)	6
14	A0514	泵浦九齿	Pump Driving Gear	1
15	A0515	螺钉	Screw (1/8-44x7.5)	3
16	B1307	曲轴	Crankshaf	1
17	A0517	滚针轴承	Needle Bearing	1
18	A0518	连杆轴承套	Thread Carrier and Hook Driving Rod (Rig	1
19	A0519	滚针轴承扣板	Needle Bearing Retaining Plate	1
20	A0151	螺钉	Screw (9/64-40x5.6)	2
21				
22				
23	A0523	针杆连杆	Needle Bar Connecting Rod	1
24	A0524	螺钉	Screw (3/16-32x14)	2
25	A0525	滚针轴承	Needle Bearing	1
26	A0526	针杆连杆销	Needle Bar Lever Connecting Rod Pin	1
27	A0527	油线	Oil Wick	1
28	A0528	螺钉	Screw (7/32-32x4)	1
29	A0529	针柱槓桿	Needle Bar Lever	1
30	A0530	螺钉	Screw (M5-0.8x5)	4
31	A0531	C形扣環	Retaining Ring	1
32	A0532	垫片	Thrust Ring	1
33	A0533	针杆连杆	Needle Bar Connecting Link	1
34	A0534	针杆连杆销	Needle Bar Connecting Link Pin	2
35	A0535	油线	Oil Wick	2
36	A0340	螺钉	Screw(1/8-44x4.5)	2
37	A0537	针杆连杆扎头	Needle Bar Connecting Bracket	1
38	A0538	螺钉	Screw (9/64-40x6.4)	3
39	A0539	针杆	Needle Bar	1
40	A0540	针古	Needle Clamp	1
41	A0541	机针	Needle	4
42	A0542	假针	Retainer	1
43	A0543	螺钉	Screw (3/32-56x2.5)	5
44	A0544	针板	Stitch Plate	1
45	A0545	针板舌头	Stitch Plate Tongue	1
46	A0546	螺钉	Screw (3/32-56x2.5)	1
47	A0547	针杆连杆组件	Needle Bar Lever, C. Set	1
48	A0548	轴套	Collar	1
49	A0556	螺钉	Screw (9/64-40x7.9)	1
50	B0650	针杆连杆销组件	Needle Bar Connecting Link Pin, C. Set	2

6

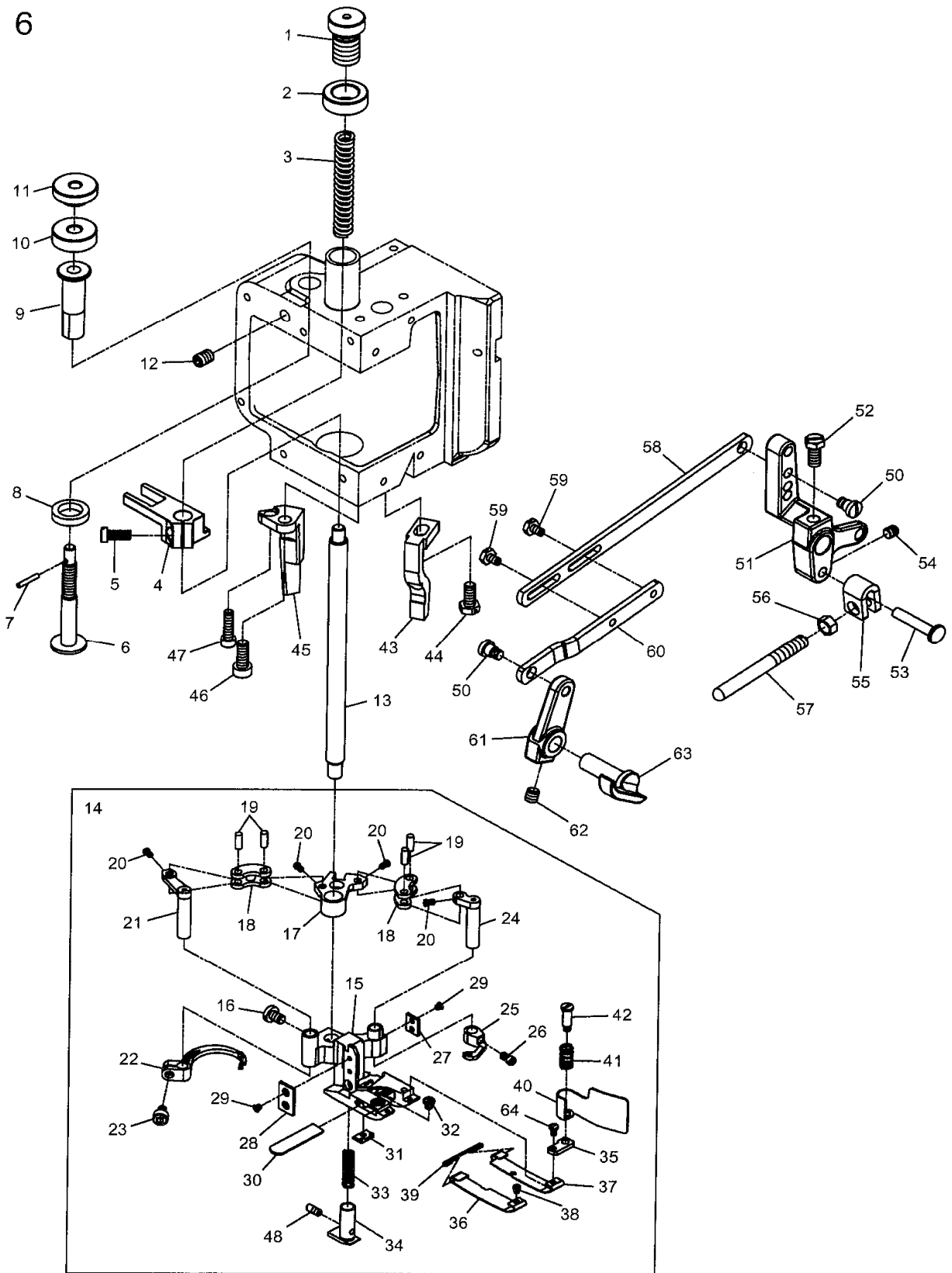

序号 Ref. N	公司件号 Parts. No	名称	Description	数量Number
1	A0601	调节螺钉	Adjusting Screw (M12-1x17)	1
2	A0602	调节螺母	Lock Nut	1
3	A0603	压脚弹簧	Presser Spring	1
4	A0604	压脚推杆支架	Presser Bar Connecting Bracket	1
5	A0103	螺钉	Screw (11/64-40x10)	1
6	A0606	压脚调节螺钉	Presser Foot Adjusting Screw	1
7	A0607	销	Pin	1
8	A0608	支架衬套	Connecting Bracket Cushion	1
9	A0609	压脚导杆	Presser Bar Guide	1
10	A0610	保险螺母	Lock Nut	1
11	A0611	调节螺母	Adjusting Nut	1
12	A0612	螺钉	Screw (M6-1x8)	1
13	A0613	压脚轴	Presser Bar	1
14	A0614	单切压脚组件	One Side Cut Presser Foot, C. Set	1
15	A0615	单切压脚	One Side Cut Presser Foot	1
16	A0616	螺钉	Screw (11/64-40x6.5)	1
17	A0617	喂针庸形片	Carrier/Hook Driving Segment	1
18	A0618	喂针连杆	Carrier/Hook Driving Lever Link	2
19	A0619	连杆销	Link Pin	4
20	A0620	螺钉	Screw (3/32-56x3.3)	4
21	A0621	喂针转动轴	Thread Hook Driving Lever	1
22	A0622	喂针线过线勾	Top Cover Thread Hook	1
23	A0623	螺钉	Screw (9/64-40x6)	1
24	A0624	喂针转动连杆轴	Top Cover Thread Carrier Driving Lever	1
25	A0625	喂针托架	Top Cover Thread Carrier	1
26	A0626	螺钉	Screw (1/8-44x5)	1
27	A0627	压脚连接片(右)	Presser Foot Attach Piece (Right)	1
28	A0628	压脚连接片(左)	Presser Foot Attach Piece (Left)	1
29	A0629	螺钉	Screw (3/32-56x2.5)	4
30	A0630	下切刀	Lower Knife	1
31	A1218	下切刀安装板	Lower Knife Clamp	1
32	A0632	螺钉	Screw (1/8-44x3.4)	1
33	A0633	压脚小弹簧	Yielding Section Spring	1
34	A0634	小盛异	Yielding Section	1
35	A0635	切角防护片座	Chip Guard Plate	1
36	A0636	压脚弹簧片(左)	Presser Foot Spring Plate (Left)	1
37	A0668	压脚弹簧片(右)	Presser Foot Spring Plate (Right)	1
38	A0638	螺钉	Screw (3/32-56x2.6)	1
39	A0639	弹簧片固定铁勾	Spring Plate Holder	1
40	A1228	切刀防护片	Chip Guard	1
41	A0641	切刀防护片弹簧	Chip Guard Spring	1
42	A0642	螺钉	Screw (1/8-44x3.4)	1
43	A0643	压脚导件(右)	Presser Foot Guide (Right)	1
44	A0644	螺钉	Screw (M5-0.8x11.7)	1
45	B0747	压脚导件(左)	Presser Foot Guide (Left)	1
46	A0646	螺钉	Screw (M5-0.8x14.1)	1
47	81427	螺钉	Screw (M4-0.7x12)	1
48	A0506	螺钉	Screw (1/8-44x5.3)	1
50	A0650	螺钉	Screw (3/16-32x4)	2
51	A0651	抬压脚连接杆(大)	Presser Bar Lifter Lever (Large)	1
52	A0652	螺钉	Screw (7/32-32x11.8)	1
53	A0653	销	Stop Plunger Segment Pin	1
54	A0403	螺钉	Screw (M5-0.8x5)	1
55	A0655	插销套	Stop Plunger Segment	1
56	A0656	螺母	Nut	1
57	A0657	压脚抬起停车柱	Presser Foot Lifter Stop Plunger	1
58	A0658	抬压脚连接杆(长)	Presser Foot Lifter Lever Link (Long)	1
59	A0659	螺钉	Screw (9/64-40x6.1)	2
60	A0660	抬压脚连接杆(短)	Presser Foot Lifter Lever Link (Short)	1
61	A0661	抬压脚连接杆(小)	Presser Bar Lifter Lever (Small)	1
62	A0662	螺钉	Screw (7/32-32x6)	1
63	A0663	压脚拉杆	Presser Bar Lifter Lever	1
64	A0664	螺钉	Screw (3/32-56x4.3)	1

7

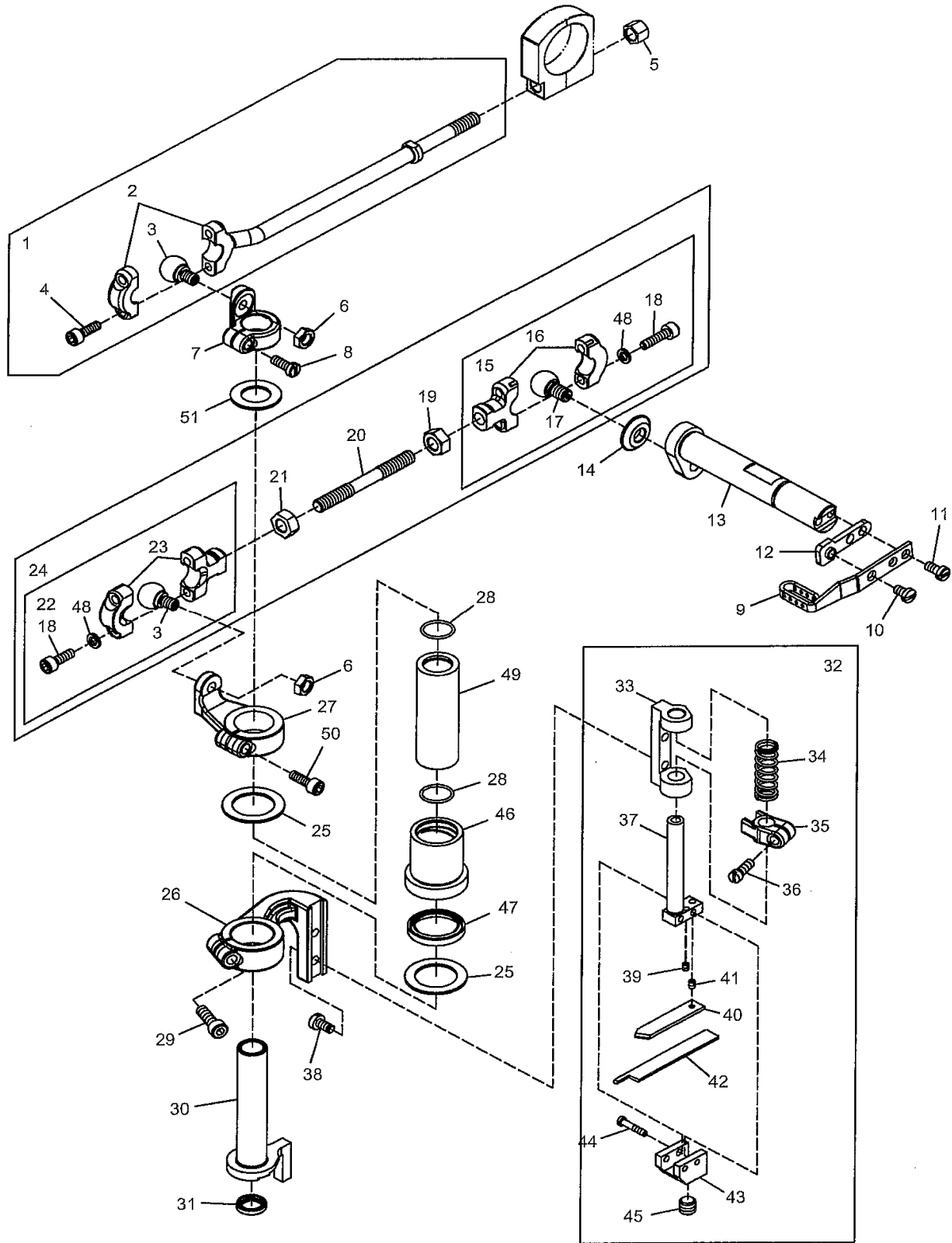

序号 Ref. N	公司件号 Parts. No	名称	Description	数量 Number
1	A0701	喂针连杆组件	Carrier/Hook Driving Rod (Left), C. Set	1
2	A0702	喂针连杆	Carrier Hook Driving Rod (Left)	1
3	A0703	喂针连杆球	Rod Ball (Left)	2
4	A0704	螺钉	Screw (9/64-40x10)	2
5	A0705	螺母	Nut	1
6	A0706	螺母	Nut	2
7	B0816	喂针连杆铜套	Carrier Hook Sleeve Lever	1
8	A0235	螺钉	Screw (9/64-40x10)	1
9	A0709	长过线架	Needle Thread Take-up	1
10	A0710	螺钉	Screw (M3.5-0.6x6)	1
11	A0711	螺钉	Screw (M3.5-0.6x7.8)	2
12	A0712	长过线架固定板	Bracket	1
13	A0713	上切刀驱动横轴	Knife Driving Lever	1
14	A0714	锁定垫片	Steady Washer	1
15	A0715	上切刀驱动连杆组件(右)	Knife Driving Connection (Right), C. Set	1
16	A0716	上切刀驱动连杆(右)	Knife Driving Connection (Right)	1
17	A0717	上切刀驱动连杆球(右)	Knife Driving Connection Ball (Right)	1
18	A0718	螺钉	Screw (M3.5-0.6x14)	4
19	A0719	螺母	Nut (Left-handed Screw)	1
20	A0720	下喂针连杆	Looper Driving Connection Rod	1
21	A0721	螺母	Nut	1
22	A0722	上切刀驱动连杆组件(左)	Knife Driving Connection (Left), C. Set	1
23	A0723	上切刀驱动连杆(左)	Feed Drive Connection (Lower)	1
24	A0724	上切刀驱动连杆组	Knife Driving Connection , C. Set	1
25	B0825	垫片	Bushing Ring	2
26	B07126	上切刀固定支架	Knife Holder Bracket	1
27	B0814	上切刀支架转轴	Knife Holder Bracket Arm	1
28	B07128	O型圈	Oil Seal	2
29	B07129	螺钉	Screw (M4-0.7x14)	1
30	B0830	喂针连杆轴	Carrier/Hook Driving Sleeve	1
31	A0731	O型圈	Oil Seal	1
32	A0732	动刀组件	Knife Holder Guide Collar, C. Set	1
33	A0733	上切刀固定座	Knife Holder Shank Support	1
34	A0734	上切刀固定座弹簧	Knife Holder Spring	1
35	A0735	弹簧固定曲柄	Knife Holder Guide Collar	1
36	A0736	螺钉	Screw (9/64-40x10.4)	1
37	A0737	上切刀固定座轴	Knife Holder Shank	1
38	A0143	螺钉	Screw (9/64-40x7.3)	2
39	A0739	螺钉	Screw (3/32-56x3.8)	1
40	A0740	动刀支架	Knife Support	1
41	A0741	螺钉	Screw (3/32-56x1.2)	1
42	A0742	动刀	Upper Knife	1
43	A0743	动刀座	Knife Holder	1
44	A0744	螺钉	Screw (3/32-56x7)	2
45	A0745	螺钉	Screw (1/4-40x6)	1
46	B0821	动刀固定座轴套	Thread Carrier and Hook Sleeve Bushing	1
47	B0823	O型圈	Oil Seal	1
48	A0863	垫片	Washer	4
49	B07149	上切刀驱动轴套	Knife Driving Shaft	1
50	A0838	螺钉	Screw (11/64-40x13)	1
51	B07151	垫片	Bushing Ring	1

8

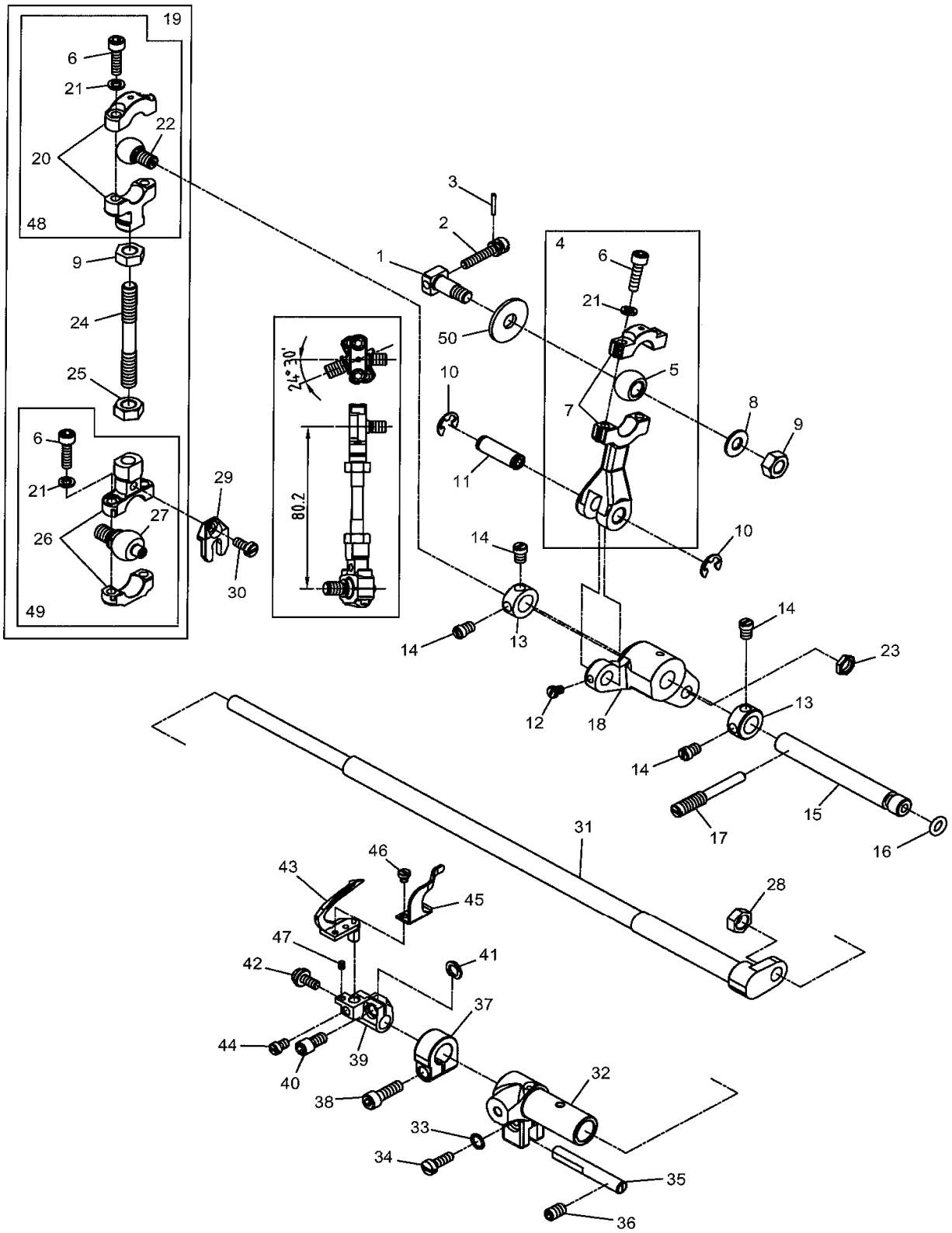

序号 Ref. N	公司件号 Parts. No	名称	Description	数量Number
1	A0801	弯针曲柄销	Looper Driving Crank Pin	1
2	A0802	螺钉	Screw (9/64-40x16.5)	1
3	A0803	销	Roll Pin for Main Shaft	1
4	A0804	弯针连杆组件	Looper Lever Driving Rod, C. Set	1
5	A0805	弯针连杆球	Looper Lever Driving Rod Ball	1
6	A0718	螺钉	Screw (M3, 5-0.6x14)	6
7	A0807	弯针连杆	Looper Lever Driving Rod	1
8	A0808	垫片	Washer	1
9	A0719	螺母(反牙)	Nut (Left-handed Screw)	2
10	A0810	开口挡圈	Retaining Ring	2
11	A0811	弯针连杆销	Looper Lever Driving Rod Pin	1
12	A0340	螺钉	Screw (1/8-44x4.5)	1
13	A0813	轴套	Collar	2
14	A0814	螺钉	Screw (11/6440x5.8)	4
15	A0815	弯针连杆轴	Looper Lever Shaft	1
16	A0862	O型圈	O-Ring	1
17	A0817	螺钉	Screw (7/32-32x15)	1
18	A0818	弯针摆动曲柄	Looper Lever	1
19	A0819	弯针连杆组件	Looper Driving Connection Rod, C. Set	1
20	A0820	弯针连杆(上)	Looper Driving Connection(Upper)	1
21	A0863	垫片	Washer	6
22	A0717	弯针连杆球(上)	Looper Driving Connection Ball(Upper)	1
23	A0823	螺母	Nut	1
24	A0720	弯针连接杆	Looper Driving Connection Rod	1
25	A0721	螺母	Nut	1
26	A0826	弯针连杆(下)	Looper Driving Connection(Lower)	1
27	A0827	弯针连杆球(下)	Looper Driving Connection Ball(Lower)	1
28	A0828	螺母	Nut	1
29	A0829	连杆比叉	Steady Fork	1
30	A0711	螺钉	Screw (M3, 5-0.6x7.8)	1
31	A0831	弯针轴	Looper Rocker Shaft	1
32	A0832	弯针轴套	Looper Rocker Shaft Sleeve	1
33	A0833	垫片	Washer	1
34	A0834	螺钉	Screw (9/64-40x10.9)	1
35	A0835	弯针轴套筒导向杆	Looper Rocker Shaft Sleeve Guide	1
36	A0836	螺钉	Screw (M5-0.8x8)	1
37	A0837	弯针轴套	Collar	1
38	A0838	螺钉	Screw (11/64-40x13)	1
39	A0839	弯针轴固定座	Looper Holder	1
40	A0840	螺钉	Screw (11/64-40x8.2)	1
41	A0841	垫片	Packing	1
42	A0842	调节螺钉	Adjusting Screw (9/64-40x8.2)	1
43	A0821	弯针	Looper	1
44	A0844	螺钉	Screw (9/64-40x4.9)	1
45	A0845	针挡(前)	Needle Guard(Front)	1
46	A0846	螺钉	Screw (29/256-48x3.2)	2
47	A0847	螺钉	Screw (3/32-56X3)	1
48	A0848	弯针连杆组件(上)	Looper Driving Connection(Upper), C. Set	1
49	A0849	弯针连杆组件(下)	Looper Driving Connection(Lower), C. Set	1
50	A0850	垫片	Spacer	1

9

LC62D

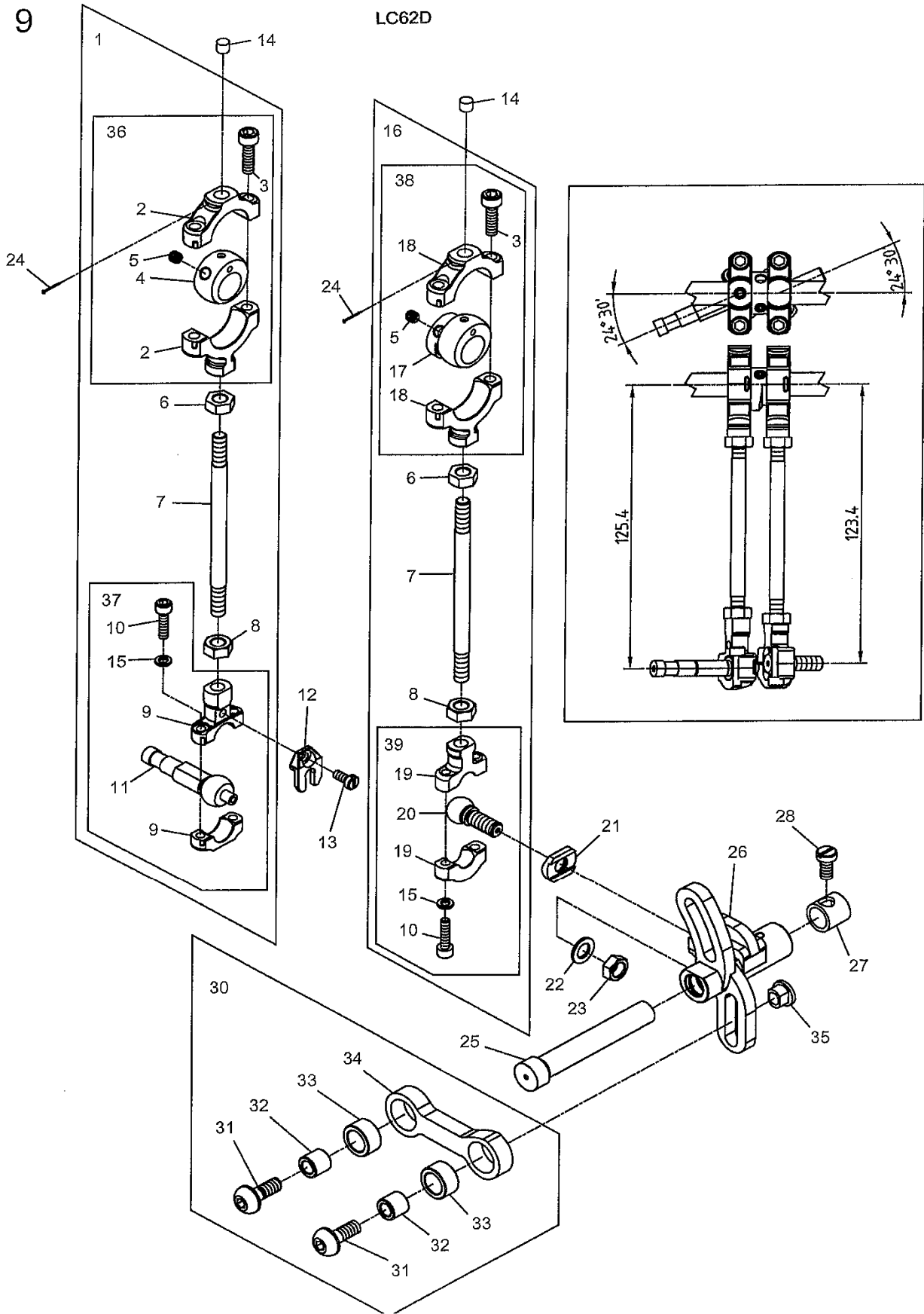

序号 Ref. N	公司件号 Parts. No	名称	Description	数量 Number
1	A0901	送料偏心连杆组件	Feed Lift Eccentric, C. Set	1
2	A0902	送料偏心连杆(上)	Feed Lift Connection (Upper)	1
3	A0903	螺钉	Screw (11/64-40x16)	4
4	A0904	送料偏心连杆球	Feed Lift Eccentric Ball	1
5	A0905	螺钉	Screw (11/64-40x4)	4
6	A0719	螺母	Nut (Left-handed Screw)	2
7	A0907	送料偏心连接杆	Feed Lift Eccentric Connecting Rod	2
8	A0721	螺母	Nut	2
9	A0826	送料偏心连杆(下)	Feed Lift Connection (Lower)	1
10	A0718	螺钉	Screw (M3.5-0.6x14)	4
11	A0911	送料偏心连杆球	Feed Lift Connection Ball	1
12	A0829	连杆比叉	Steady Fork	1
13	A0711	螺钉	Screw (M3.5-0.6x7.8)	1
14	B1014	油线	Oil Wick	2
15	A0863	垫片	Washer	4
16	A0916	送料偏心连杆组件	Feed Drive Eccentric, C. Set	1
17	A0917	送料偏心连杆球	Feed Drive Eccentric Ball	1
18	A0918	送料偏心连杆(上)	Feed Lift Connection (Upper)	1
19	A0723	送料偏心连杆(下)	Feed Drive Connection (Lower)	1
20	A0920	送料偏心连杆球	Feed Drive Connection Ball	1
21	A0921	垫片	Steady Washer	1
22	A0922	垫片	Washer	1
23	A0828	螺母	Nut	1
24	B0924	销	Pin	2
25	A0925	送料轴	Feed Drive Shaft	1
26	A0926	送料曲柄	Feed Drive/Looper Avoid Lever	1
27	A0927	送料轴套筒	Feed Drive Shaft Bushing	1
28	A0928	螺钉	Screw (3/16-32x10.5)	1
29				
30	A0930	差动调节连杆组件	Looper Avoid Connecting Rod, C. Set	1
31	A0931	螺钉	Screw (7/32-32x10)	2
32	A0932	连杆轴承衬套	Looper Avoid Connecting Rod Bushing	2
33	A0933	轴承	Needle Bearing	2
34	A0934	差动调节连杆	Looper Avoid Connecting Rod	1
35	A0935	调整螺母	Looper Aviod Adjusting Nut	1
36	A0936	送料偏心连杆组件(上)	Feed Lift Connection (Upper), C. Set	1
37	A0937	送料偏心连杆组件(下)	Feed Lift Connection (Lower), C. Set	1
38	A0938	送料偏心连杆组件(上)	Feed Drive Eccentric (Upper), C. Set	1
39	A0939	送料偏心连杆组件(下)	Feed Drive Eccentric (Lower), C. Set	1

9

LC62D

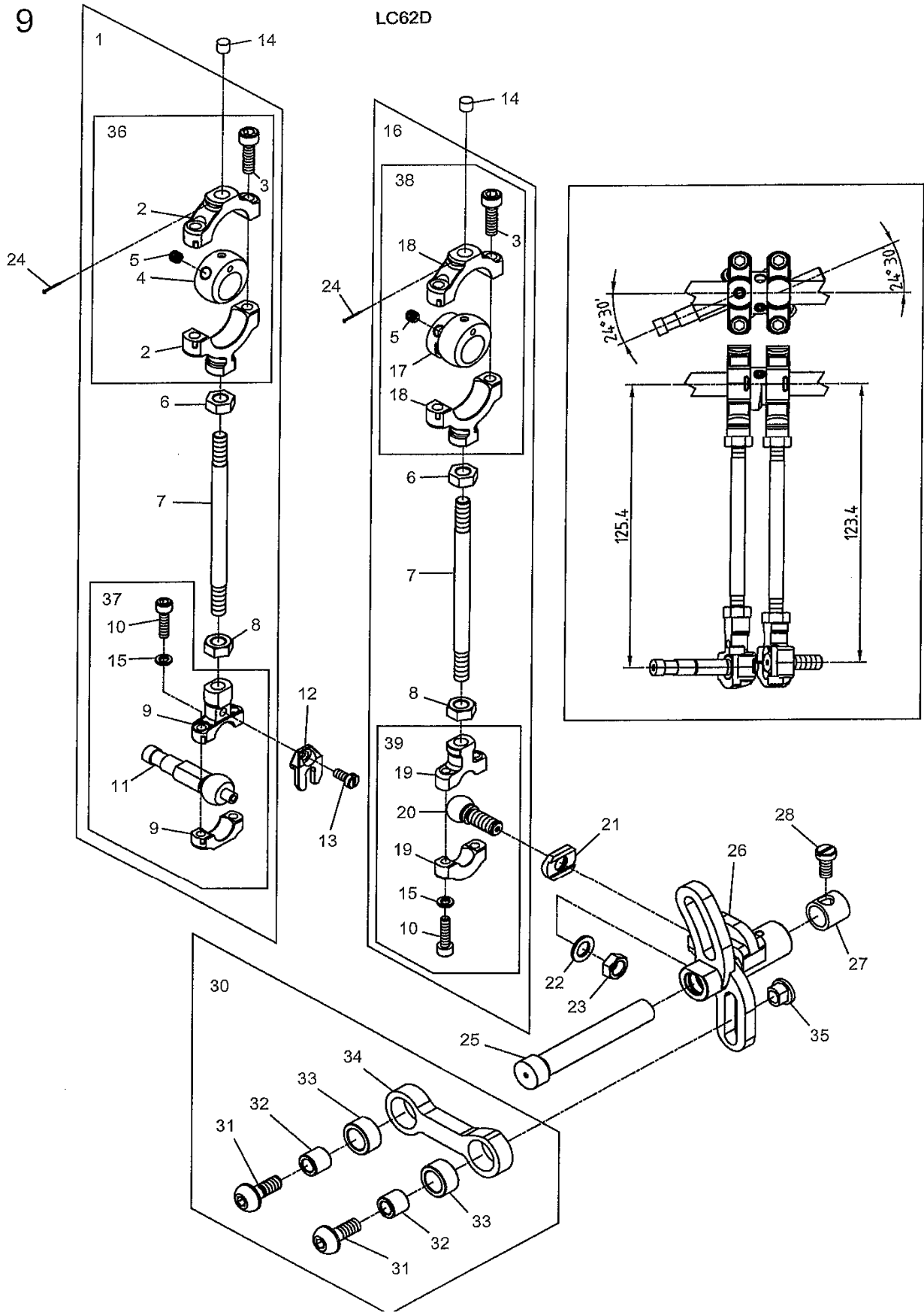

序号 Ref. N	公司件号 Parts. No	名称	Description	数量 Number
1	A0901	送料偏心连杆组件	Feed Lift Eccentric, C. Set	1
2	A0902	送料偏心连杆(上)	Feed Lift Connection (Upper)	2
3	A0903	螺钉	Screw (11/64-40x16)	4
4	A0904	送料偏心连杆球	Feed Lift Eccentric Ball	1
5	A0905	螺钉	Screw (11/64-40x4)	4
6	A0719	螺母	Nut (Left-handed Screw)	2
7	A0907	送料偏心连接杆	Feed Lift Eccentric Connecting Rod	2
8	A0721	螺母	Nut	2
9	A0826	送料偏心连杆(下)	Feed Lift Connection (Lower)	1
10	A0718	螺钉	Screw (M3.5-0.6x14)	4
11	A0911	送料偏心连杆球	Feed Lift Connection Ball	1
12	A0829	连杆比叉	Steady Fork	1
13	A0711	螺钉	Screw (1\43.5-0.6x7.8)	1
14	B1014	油线	Oil Wick	2
15	A0863	垫片	Washer	4
16	A0916	送料偏心连杆组件	Feed Drive Eccentric, C. Set	1
17	A0917	送料偏心连杆球	Feed Drive Eccentric Ball	1
18	A0938	送料偏心连杆组件(上)	Feed Drive Eccentric (Upper), C. Set	1
19	A0723	送料偏心连杆(下)	Feed Drive Connection (Lower)	1
20	A0920	送料偏心连杆球	Feed Drive Connection Bail	1
21	A0921	垫片	Steady Washer	1
22	A0922	垫片	Washer	1
23	A0828	螺母	Nut	1
24	B0924	销	Pin	2
25	A0925	送料轴	Feed Drive Shaft	1
26	B09126	送料曲柄	Feed Drive/Looper Avoid Lever	1
27	B09127	送料轴套筒	Feed Rocker Shaft Bushing	1
28	C02026	螺钉	Screw (M4^0.7x5)	1
29	A0939	送料偏心连杆组件(下)	Feed Drive Eccentric (Lower), C. Set	1
30	A0930	差动调节连杆组件	Looper Avoid Connecting Rod, C. Set	1
31	A0931	螺钉	Screw (7/32-32x10)	2
32	A0932	连杆轴承衬套	Looper Avoid Connecting Rod Bushing	2
33	A0933	轴承	Needle Bearing	2
34	A0934	差动调节连杆	Looper Avoid Connecting Rod	1
35	A0935	调整螺母	Looper Avlod Adjusting Nut	1
36	A0936	送料偏心连杆组件(上)	Feed Lift Connection (Upper), C. Set	1
37	A0937	送料偏心连杆组件(下)	Feed Lift Connection (Lower), C. Set	1

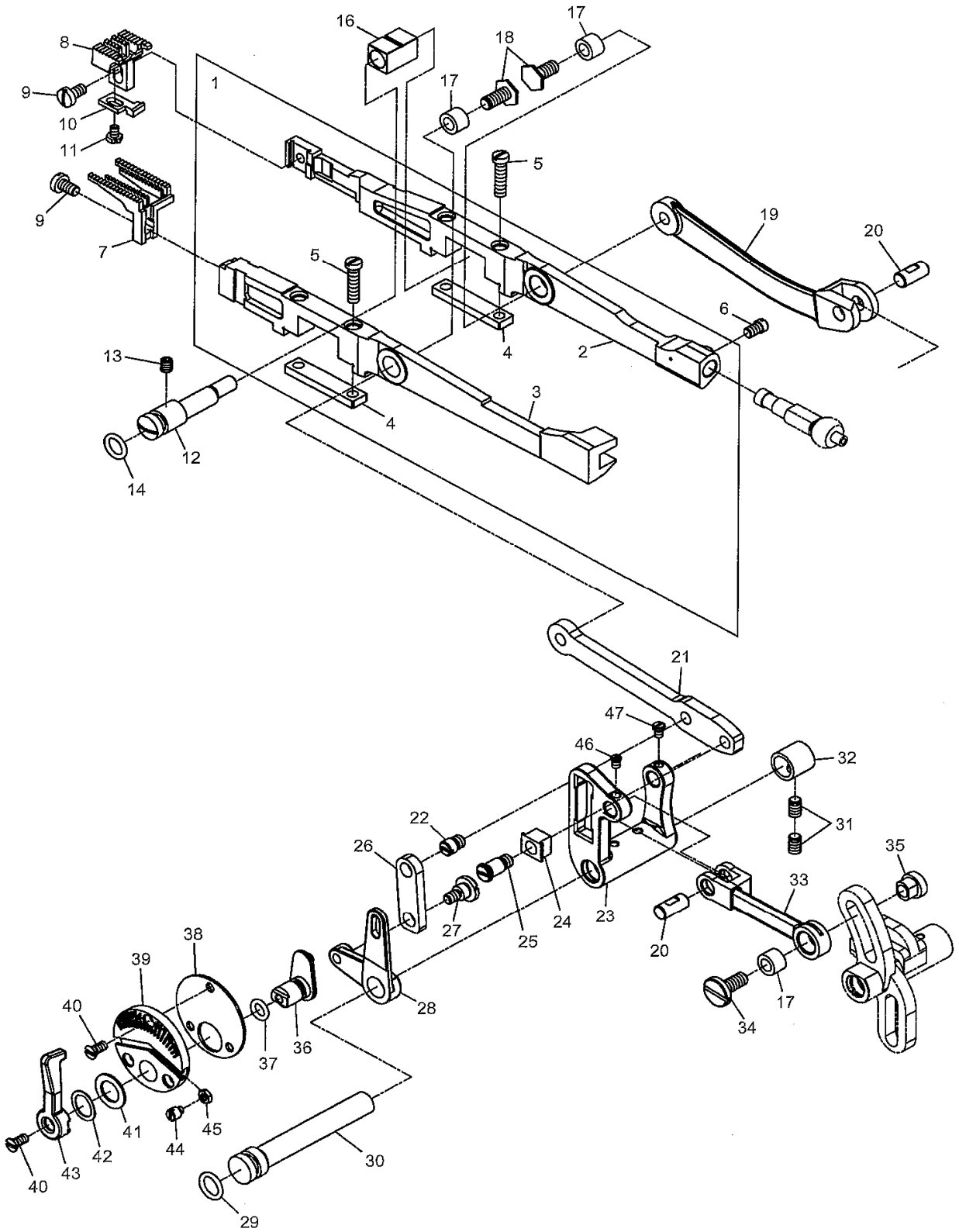

序号 Ref. N	公司件号 Parts. No	名称	Description	数量Number
1	A1001	送料轴组件	Feed Bar, C. Set	1
2	A1002	主送料轴固定座	Main Feed Bar	1
3	A1003	差动送料轴固定座	Differential Feed Bar	1
4	A1004	送料轴固定片	Feed Bar Plate	2
5	A1005	螺钉	Screw (11/6440x18.3)	4
6	A1006	螺钉	Screw (11/64-40x6.4)	1
7	A1007	差动齿	Differential Feed Dog	1
8	A1008	主送齿	Main Feed Dog	1
9	A1009	螺钉	Screw (11/64-40x8)	2
10	A1010	顶针片(后)	Needle Guard (Rear)	1
11	A1011	螺钉	Screw (1/8-44x4.8)	1
12	A1012	送料轴偏心销	Feed Bar Eccentric Pin	1
13	A0508	螺钉	Screw (11/64-40x5.8)	1
14	A1014	O型圈	O-ring (P8)	1
15				
16	A1016	送料轴滑块	Feed Bar Slide Block	1
17	A1017	送料轴曲柄套筒	Feed Rocker Link Bushing	3
18	A1018	螺钉	Screw (7/32-32x6.5)	2
19	A1019	主送料轴曲柄	Main Feed Bar Driving Link	1
20	A1020	主送料轴曲柄销	Feed Rocker Link Pin	2
21	A1021	主送料轴驱动杆	Differential Feed Bar Driving Link	1
22	A1022	螺钉	Screw (7/32-32x5)	1
23	A1023	送料轴摇杆	Feed Rocker	1
24	A1024	差动送料轴调节滑块	Differential Feed Bar Driving Link Slider	1
25	A1025	螺钉	Screw (7/32-32x4,6)	1
26	A1026	差动送料轴调节杆	Differential Feed Adjusting Link	1
27	A1027	螺钉	Screw (11/64-40x6.6)	1
28	A1028	差动送料轴调节横曲柄	Differential Feed Adjusting Lever	1
29	A1029	O型圈	O-ring (P9)	1
30	A1030	送料调节轴	Feed Rocker Shaft	1
31	A0836	螺钉	Screw (M5-0.8x8)	2
32	A0927	送料调节轴套筒	Feed Rocker Shaft Bushing	1
33	A1033	送料轴连杆	Feed Rocker Link	1
34	A1034	螺钉	Screw (7/32-32x10.5)	1
35	A1035	送料轴调节螺母	Feed Adjusting Nut	1
36	A1036	差动送料轴调节横杆(中)	Differential Feed Adjusting Lever (Middle)	1
37	A1037	O型圈	O-ring (P6)	1
38	A1038	差动调节刻度盘垫片	Differential Feed Adjusting Dial Gasket	1
39	A1039	差动送料轴调节刻度表盘	Differential Feed Adjusting Dial	1
40	A0214	螺钉	Screw (9/64-40x7.7)	4
41	A1041	垫片	Spacer (Fiber)	1
42	A1042	波形垫片	Corrugated Washer	1
43	A1043	差动送料轴调节操作杆	Differential Feed Operating Lever	1
44	A1044	螺钉	Screw (M3-0.5x2.8)	2
45	A1045	螺母	Nut	2
46	A1046	螺钉	Screw (1/8-44x4)	1
47	A0340	螺钉	Screw (1/8-44x4.5)	1

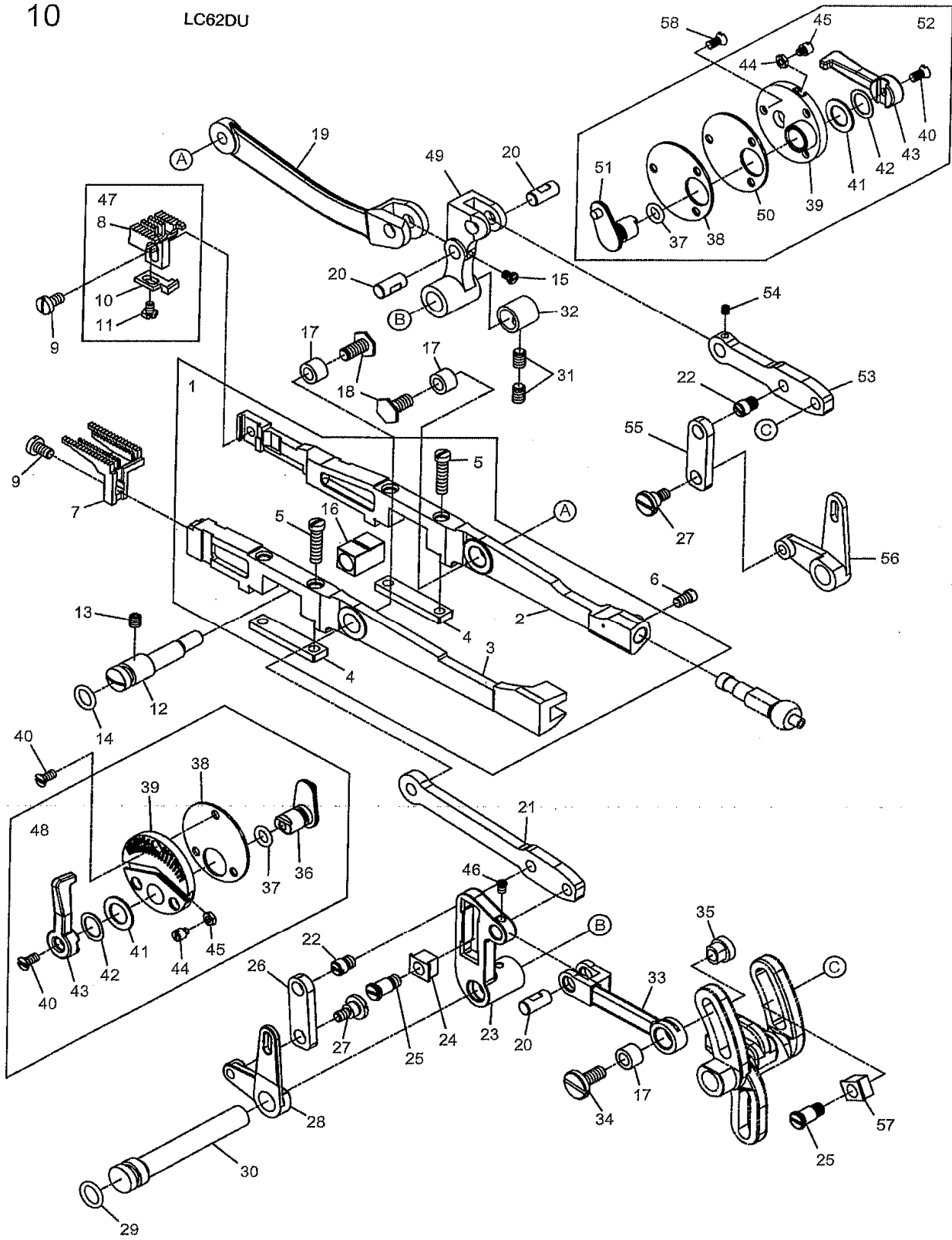

序号 Ref. N	公司件号 Parts. No	名称	Description	数量Number
1	A1001	送料轴组件	Feed Bar, C. Set	1
2	A1002	主送料轴固定座	Main Feed Bar	1
3	A1003	差动送料轴固定座	Differential Feed Bar	1
4	A1004	送料轴固定片	Feed Bar Plate	2
5	A1005	螺钉	Screw (11/64-40x18.3)	4
6	A1006	螺钉	Screw (11/64-40x6.4)	1
7	A1007	差动齿	Differential Feed Dog	1
8	A1008	主送齿	Main Feed Dog	1
9	A1009	螺钉	Screw (11/64-40x8)	2
10	A1010	顶针片(后)	Needle Guard (Rear)	1
11	A1011	螺钉	Screw (1/8-44x4.8)	1
12	A1012	送料轴偏心销	Feed Bar Eccentric Pin	1
13	A0508	螺钉	Screw (11/64-40x5.8)	1
14	A1014	O型圈	O-ring (P8)	1
15	A0340		Screw(1/8-44x4.5)	1
16	A1016	送料轴滑块	Feed Bar Slide Block	1
17	A1017	送料轴曲柄套筒	Feed Rocker Link Bushing	3
18	A1018	螺钉	Screw (7/32-32x6.5)	2
19	A1019	主送料轴曲柄	Main Feed Bar Driving Link	1
20	A1020	主送料轴曲柄销	Feed Rocker Link Pin	3
21	A1021	主送料轴驱动杆	Differential Feed Bar Driving Link	1
22	A1.022	螺钉	Screw (7/32-32x5)	2
23	B10123	送料轴摇杆	Feed Rocker	1
24	A1024	差动送料轴调节滑块	Differential Feed Bar Driving Link Slider	1
25	A1025	螺钉	Screw (7/32-32x4.6)	2
26	A1026	差动送料轴调节杆	Differential Feed Adjusting Link	1
27	A1027	螺钉	Screw (11/64-40x6.6)	2
28	A1028	差动送料轴调节横曲柄	Differential Feed Adjusting Lever	1
29	A1029	O型圈	O-ring (P9)	1
30	A1030	送料调节轴	Feed Rocker Shaft	1
31	A0836	螺钉	Screw (M5 [~] 0.8x8)	2
32	A0927	送料调节轴套筒	Feed Rocker Shaft Bushing	1
33	A1033	送料轴连杆	Feed Rocker Link	1
34	A1034	螺钉	Screw (7/32-32x10.5)	1
35	A1035	送料轴调节螺母	Feed Adjusting Nut	1
36	A1036	差动送料轴调节横杆(中)	Differential Feed Adjusting Lever	1
37	A1037	O型圈	O-ring (P6)	2
38	A1038	差动调节刻度盘垫片	Differential Feed Adjusting Dial Gasket	2
39	A1039	差动送料轴调节刻度表盘	Differential Feed Adjusting Dial	2
40	A0214	螺钉	Screw (9/64-40x7.7)	5
41	A1041	垫片	Spacer(Fiber)	2
42	A1042	波形垫片	Corrugated Washer	2
43	A1043	差动送料轴调节操作杆	Differential Feed Operating Lever	2
44	A1044	螺钉	Scrs w(M3-0.5x2.8)	4
45	A1045	螺母	Nut	4
46	A1046	螺钉	Screw(1/8-44x4)	1
47	B10047	主送料齿组件	Main Feed Dog, C. Set	1
48	B10048	差动送料轴调节刻度表盘组件	Differential Feed Adjusting Dial, C. Set	1
49	B10049	送料轴摇杆	Feed Rocker	1
50	B10050	差动调节刻度盘垫片	Differential Feed Adjusting Dial Gasket	1
51	B10051	差动送料轴调节横杆	Differential Feed Adjusting Lever	1
52	B10052	差动送料轴调节刻度表盘组件	Differential Feed Adjusting Dial, C. Set	1
53	B10053	差动送料轴驱动杆	Differential Feed Bar Driving Link	1
54	C01014	螺钉	Screw (M3-0.5x3)	1
55	B10055	差动送料轴调节连杆	Differential Feed Adjusting Link	1
56	B10056	差动送料轴调节横杆	Differential Feed Adjusting Lever	1
57	B10057	差动送料轴调节滑块	Differential Feed Bar Driving Link Slider	1
58	A0151	螺钉	Screw (9/64-40x5.6)	3

11

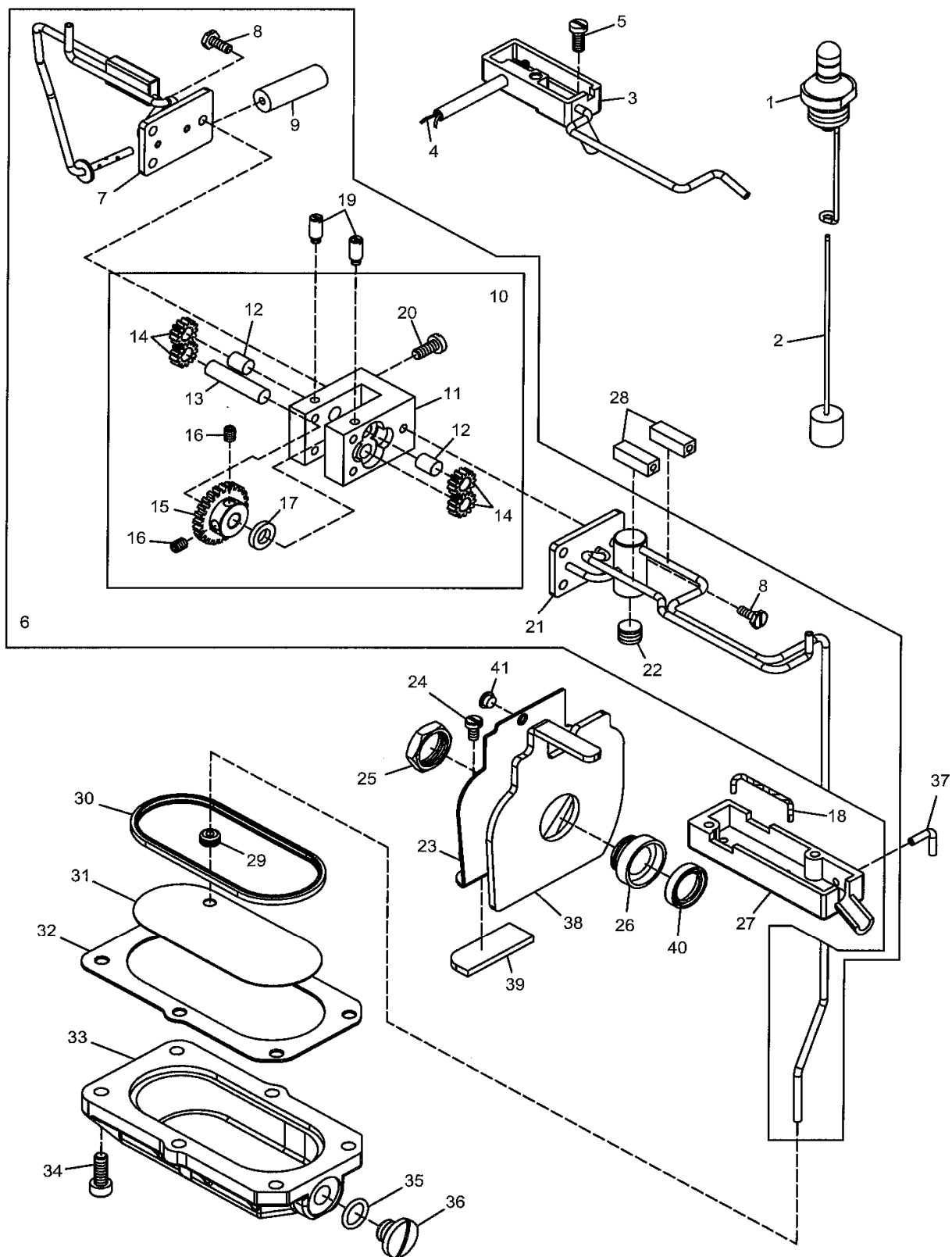

序号 Ref. N	公司件号 Parts. No	名称	Description	数量 Number
1	A1101	游标	Crank Chamber Oil Gauge Unit	1
2	A1102	油量指示棒	Oil Height Indicator	1
3	B11103	油量接收器(后)	Oil Receiver (Rear)	1
4	A1104	油线	Oil Wick	1
5	A0103	螺钉	Screw (11/64-40x10)	1
6	B11106	油泵组件(后)	Pump, C. Set	1
7	B11107	吸油管组件(后)	Pump Housing Cover (Rear) Unit	1
8	A1108	螺钉	Screw (9/64-40x9.7)	6
9	A1109	吸油毡	In-take Filter	1
10	A1110	油泵组件(后)	Pump, C. Set	1
11	A1111	油泵齿轮支架	Pump Housing	1
12	A1112	油泵齿轮(短)	Pump Gear Shaft (Short)	2
13	A1113	油泵组件(长)	Pump Gear Shaft (Long)	1
14	A1114	油泵齿轮	Oil Pump Gear	4
15	A1115	油泵驱动齿轮	Pump Driven Gear	1
16	A0508	螺钉	Screw (11/64-40x5.8)	2
17	A0428	油封	Oil Seal	1
18	B1218	油线	Oil Wick	1
19	A1119	螺钉	Screw (9/64-40x3)	2
20	A1120	螺钉	Screw (11/64-40x10)	2
21	B11121	吸油管组件(前)	Pump Housing Cover (Front) Unit	1
22	A1122	螺钉	Screw (M10-1.5x6.1)	1
23	A1123	防油板	Thread Take-up Oil Defender Unit	1
24	A0143	螺钉	Screw (9/64-40x7.3)	1
25	B11125	螺母	Nut	1
26	B11126	螺钉	Screw	1
27	B11127	油量接收器(前)	Oil Receiver (Front)	1
28	A1142	防油套	Oil Tube Support	2
29	A1129	橡胶套筒	Rubber Bushing	1
30	A1130	过滤油网橡胶油封	Oil Filter Screen Rubber Seal	1
31	A1131	过滤油网	Oil Filter Screen	1
32	A1132	油槽防油垫	Oil Reservoir Gasket	1
33	A1133	油槽	Oil Reservoir	1
34	A0646	螺钉	Screw (M5-0.8x14)	6
35	B11035	O型圈	O-ring (P10)	1
36	A0129	螺钉	Drain Hole Screw (3/8-24x8)	1
37	A1137	铜管	Copper Tube	1
38	B11138	防油板	Thread Take-up Oil Defender Unit	1
39	A1139	防油板毡	Thread Take-up Oil Defender Unit	1
40	B11140	油封	Oil Seal	1
41	C02020	止油孔塞	Seal Plug(04.9x4.3)	1

LC62D-12MR

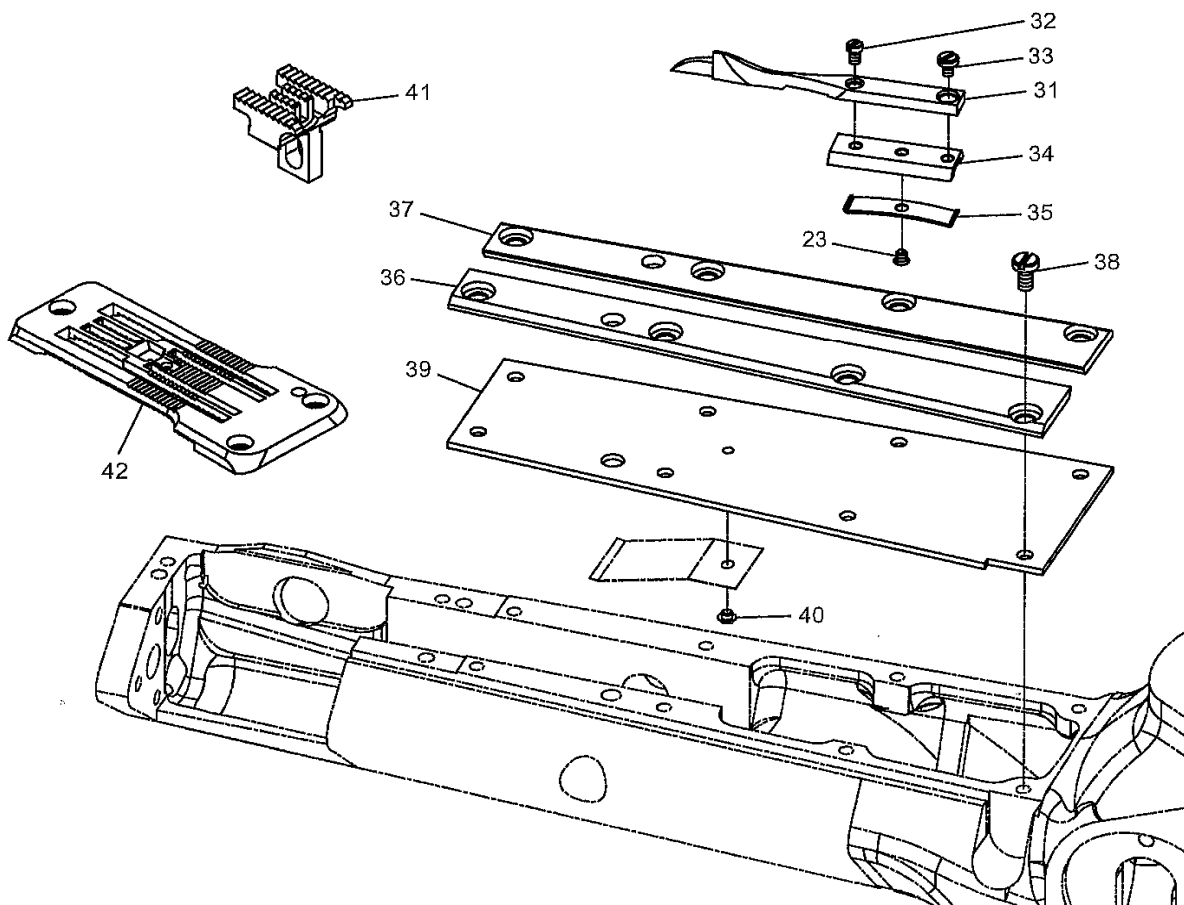
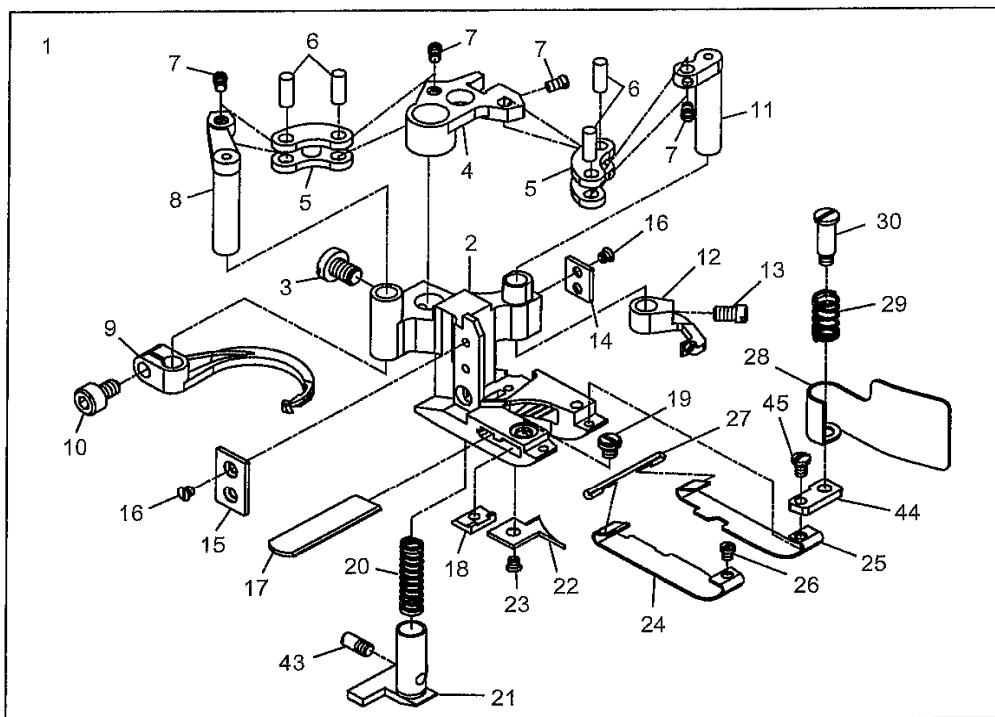

序号 Ref. N	公司件号 Parts. No	名称	Description	数量 Number
1	A1201	双切压脚组件	Double Side Cut Presser Foot, C. Set	1
2	A1202	双切压脚	Double Side Cut Presser Foot	1
3	A0616	螺钉	Screw (11/64-40x6.5)	1
4	A0617	喂针驱动扇形片	Carrier/Hook Driving Segment	1
5	A0618	喂针驱动连杆	Carrier/Hook Driving Lever Link	2
6	A0619	连杆销	Link Pin	4
7	A0620	螺钉	Screw (3/32-56x3.4)	4
8	A0621	喂针驱动连杆	Thread Hook Driving Lever	1
9	A0622	喂针线过线勾	Top Cover Thread Hook	1
10	A0623	螺钉	Screw (9/64-40x6.4)	1
11	A0624	喂针线托架驱动横杆	Top Cover Thread Carrier Driving Lever	1
12	A0625	喂针线过线勾	Top Cover Thread Carrier	1
13	A0626	螺钉	Screw (1/8-44x5)	1
14	A0627	压脚连接片(右)	Presser Foot Attach Piece (Right)	1
15	A0628	压脚连接片(左)	Presser Foot Attach Piece (Left)	1
16	A0629	螺钉	Screw (3/32-56x2.5)	4
17	A0630	下切刀	Lower Knife	1
18	A1218	下切刀夹片	Lower Knife Clamp	1
19	A0632	螺钉	Screw (1/8-44x3.4)	1
20	A0633	小压脚弹簧	Yielding Section Spring	1
21	A1221	小压脚弹簧	Yielding Section	1
22	A1222	压脚舌头	Presser Foot Tongue	1
23	A1223	螺钉	Screw (3/32-56x2.8)	2
24	B12124	压脚弹簧片(左)	Presser Foot Spring Plate (Left)	1
25	B12125	压脚弹簧片(右)	Presser Foot Spring Plate (Right)	1
26	A0638	螺钉	Screw (3/32-56x2.6)	1
27	A0639	弹簧片固定板	Spring Plate Holder	1
28	A1228	切角防护片	Chip Guard	1
29	A0641	切角防护片弹簧	Chip Guard Spring	1
30	A0642	螺钉	Screw (1/8-44x3.4)	1
31	A1231	前导布器(薄料用)	Lap Former	1
32	A1232	螺钉	Screw (3/32-56x3.8)	1
33	A1233	螺钉	Screw (3/32-56x3.8)	1
34	A1234	前导布器滑块	Lap Former Slide Block	1
35	A1235	前导布器滑块弹簧片	Lap Former Slide Block Spring	1
36	A1236	前导布器导轨(左)	Lap Former Guide Plate (Left)	1
37	A1237	前导布器导轨(右)	Lap Former Guide Plate (Right)	1
38	A0218	螺钉	Screw (1/8-44x6.5)	8
39	A1239	下巴盖板	Sewing Cylinder Cover (Upper)	1
40	A0220	螺钉	Screw (3/32-56x2.1)	1
41	A1241	主齿	Main Feed Dog	1
42	A1242	针板	Stitch Plate	1
43	A0506	螺钉	Screw (1/8-44x5.3)	1
44	A0635	切角防护片座	Chip Guard Plate	1
45	A0664	螺钉	Screw (3/32-56x4.3)	1

13

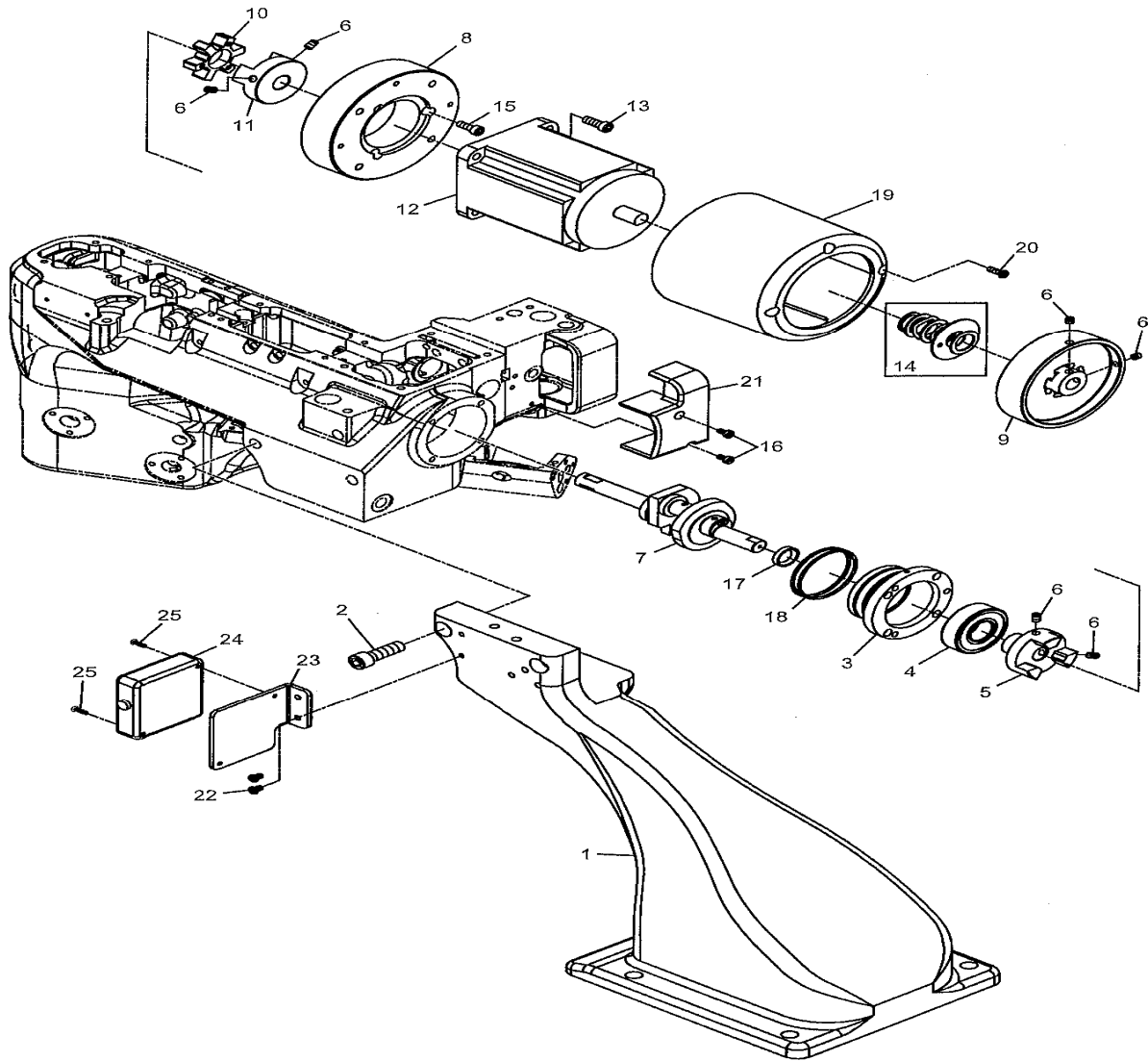

序号 Ref. N	公司件号 Parts. No	名称	Description	数量 Number
1	B2534	机座	Sewing Maching Supprting Block	1
2	A1302	螺钉	Screw (3/8-16x30)	2
3	B1303	轴承固定座	Bearing Housing	1
4	A0404	轴承	Ball Bearing	1
5	B1305	轴承轴心	Adapter	1
6	A0836	螺钉	Screw (M5-0.8x8)	6
7	B1307	曲轴	Crankshaf	1
8	B2540	电机座	Moter Support	1
9	A1309	电机手轮	Handwheel	1
10	B1310	联轴器(中)	Coupling (Middle)	1
11	B1311	联轴器(后)	Coupling (Rear)	1
12	B1312	伺服电机	Servo Moter	1
13	B1313	螺钉	Screw (M6-1x16)	4
14	B1314	感应板组件	Sensor Plate, C. Set	1
15	A0646	螺钉	Screw (M5-0.8x14)	3
16	A0834	螺钉	Screw (9/64-40x11)	3
17	B0508	油封	Oil Seal	1
18	B0507	O型圈	O-Ring	2
19	B2567	电机罩	Motor Cover	1
20	C01011	螺钉	Screw (M4-0.7x10)	3
21	B2569	护罩	Cover	1
22	B2530	螺钉	Screw (M4-0.7x8)	2
23	B2520	手轮支架	Handwheel Support	1
24	B13124	电子手轮	Electron Handwheel	1
25	B13125	螺钉	Screw (M3-0.5x15)	2

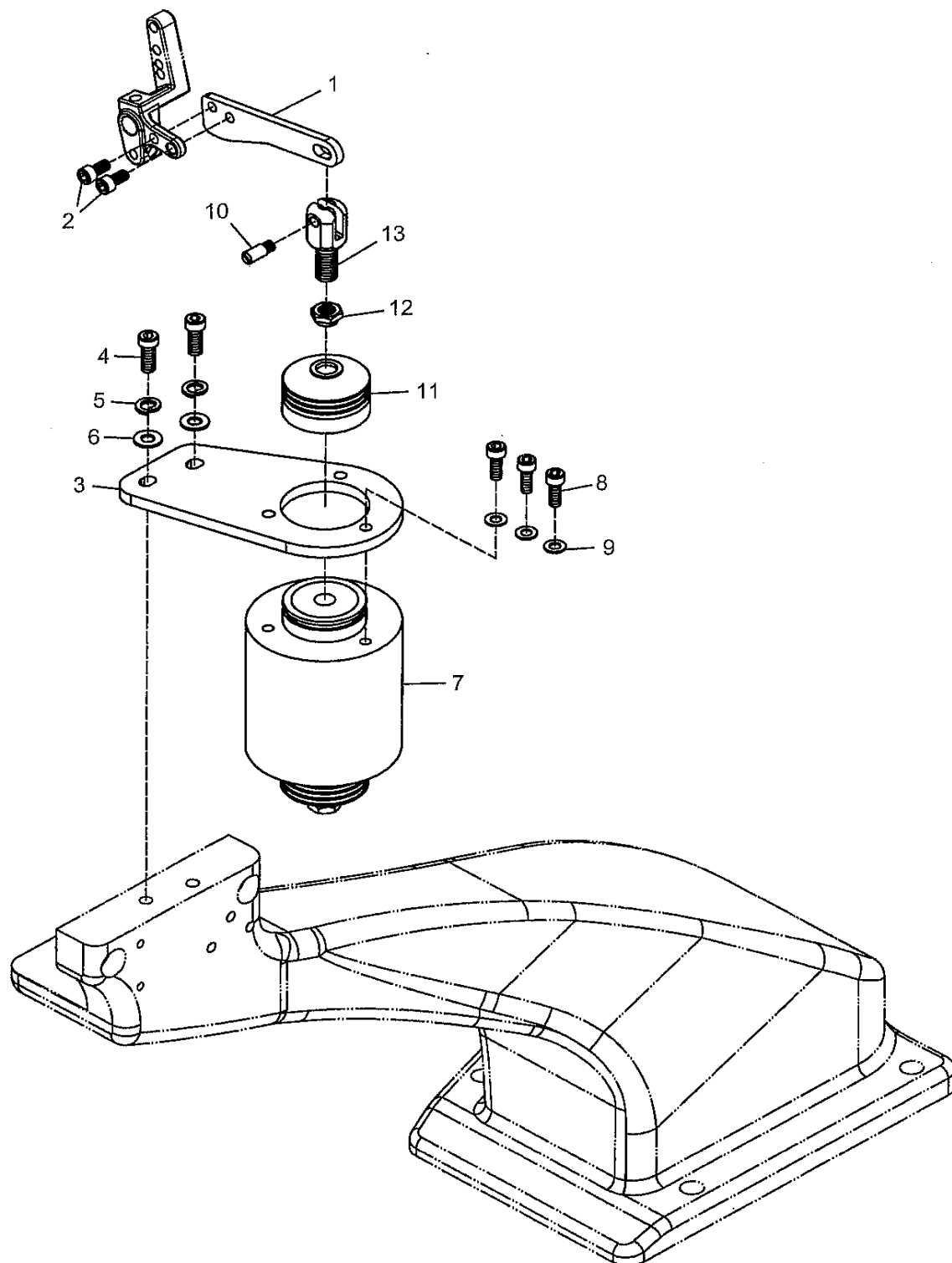

序号 Ref. N	公司件号 Parts. No	名称	Description	数量 Number
1	B2572	抬压脚连杆	Presser Bar Lifter Lever	1
2	B1402	螺钉	Screw (M5-0.8x10)	2
3	B2571	电磁铁固定板	Electromagnet Support Plate	1
4	B1313	螺钉	Screw (M6-1x16)	2
5	B1435	弹簧垫片	Spring Washer	2
6	B2522	垫片	Washer	2
7	B2570	电磁铁	Electromagnet	1
8	A0646	螺钉	Screw (M5-0.8x14)	3
9	B2524	垫片	Washer	3
10	B1410	螺钉	Screw (M5-0.8x5)	1
11	B14211	防震垫	Dust Cover	1
12	B1412	螺母	Nut	1
13	B2519	Y型接头	"Y" Joint	1

15

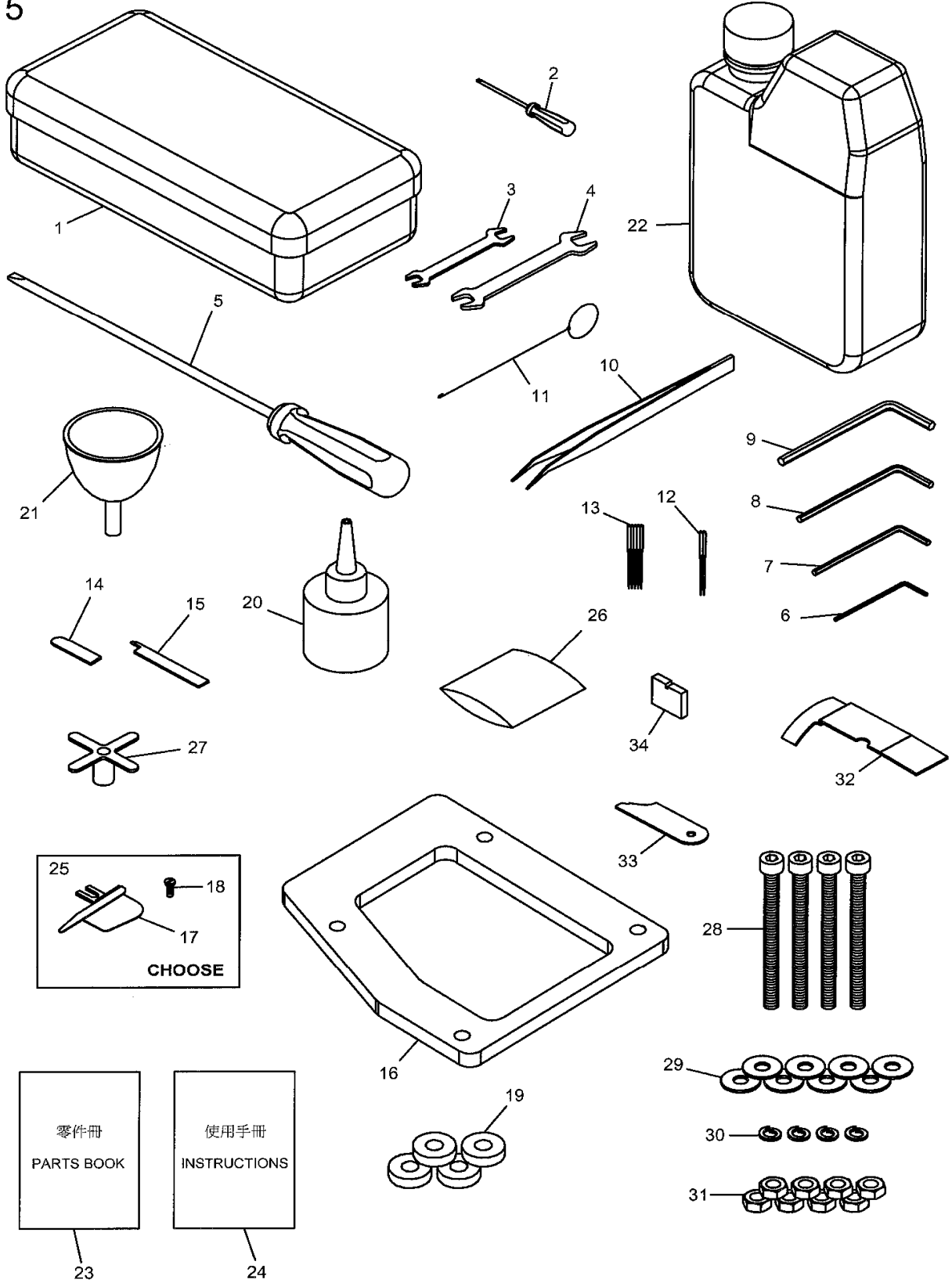

序号 Ref. N	公司件号 Parts. No	名称	Description	数量Number
1	B1501	附件盒	Attachment Box	1
2	B1502	螺丝刀	Screwdriver	1
3	B1503	扳手(5.5mm-7mm)	Wrench (5.5mm-7mm)	1
4	B1504	扳手(8mm-10mm)	Wrench (8mm-10mm)	1
5	B1505	螺丝刀	Screwdriver	1
6	B1506	内六角扳手(1.5mm)	Hexagonal Wrench (1,5mm)	1
7	B1507	内六角扳手(2.5mm)	Hexagonal Wrench (2.5mm)	1
8	B1508	内六角扳手(3mm)	Hexagonal Wrench (3mm)	5
9	B1509	内六角扳手(4mm)	Hexagonal Wrench (4mm)	1
10	B1510	镊子	Thread Tweezers	1
11	B1511	穿线铁丝	Threading Wire	1
12	A0542	假针	Retainer	2
13	A0541	真针	Needle	5
14	A0630	下切刀	Lower Knife	1
15	A0742	上切刀片	Upper Knife	1
16	B15316	减震垫	Supporting Board Rubber Cushion	1
17	B1517	导布器	Folder	1
18	B1518	螺钉	Screw (1/8-44x13)	1
19	C17004	减震垫	Supporting Board Rubber Cushion	4
20	B1520	油壶	Oiler	1
21	B1521	漏斗	Funnel	1
22	B1522	润滑油	Oil	1
23	B1523	零件手册	Parts List	1
24	B1524	说明书	Instruction Manual	1
25	B1525	导布器组件	Folder, C. Set	1
26	B1526	干燥剂	Drier	1
27	B1527	稳定套	Stable Cap	6
28	B15128	螺钉	Screw (M8-1.25x100)	4
29	B15129	垫片	Washer	8
30	B15130	弹簧垫片	Spring Washer	4
31	B15131	螺母	Nut	8
32	B2508	平行定规	Parallel Rule	1
33	B2505	退距定规	Distance Rule	1
34	B2506	高度定规	Height Rule	1

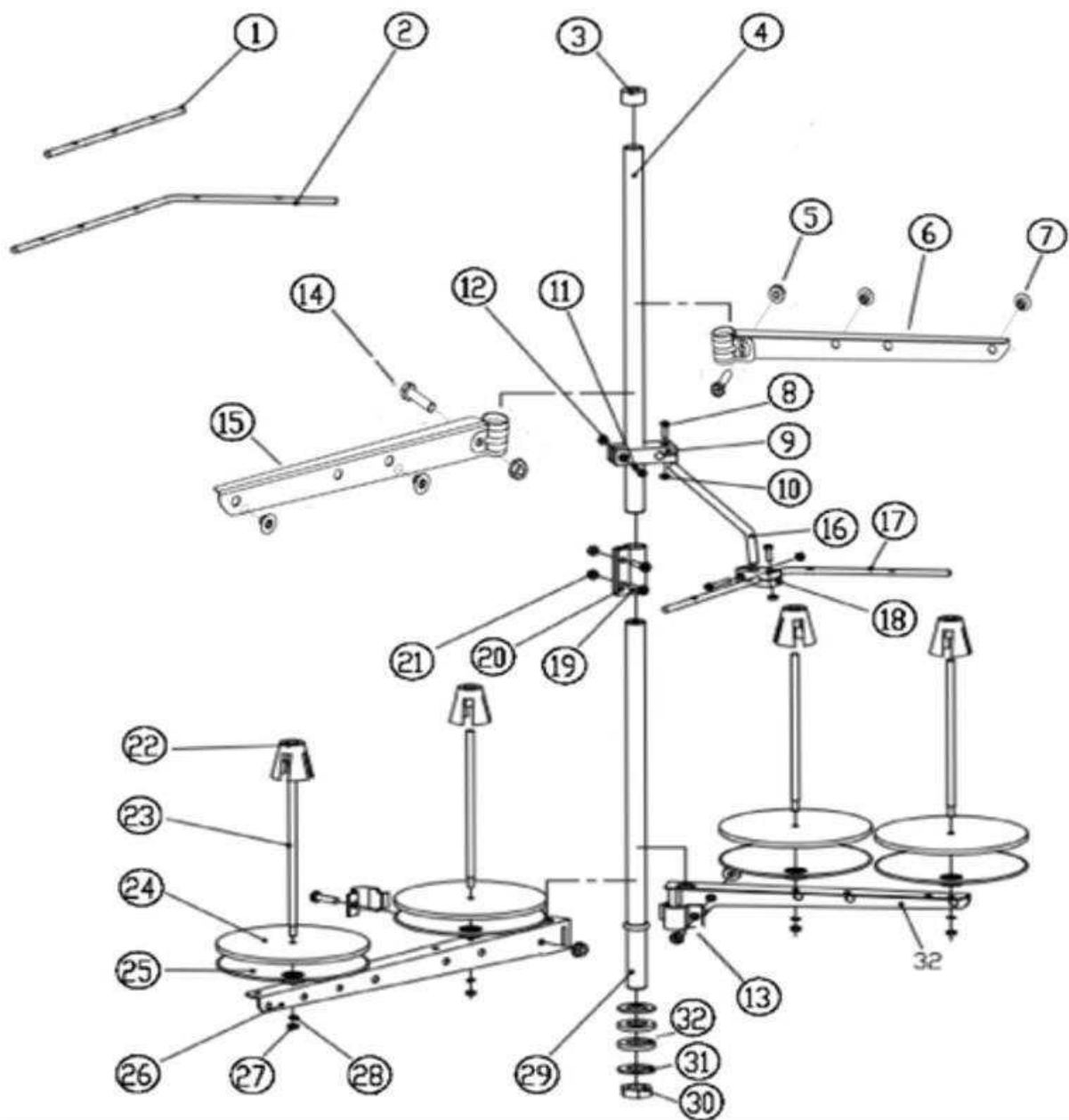

序号 Ref. N	公司件号 Parts. No	名称	Description	数量Number
1	20631018	过线棒	Thread guide	0
2	30113019	过线棒	Thread guide	1
3	20131019	棒帽	Rod cap	1
4	121131009	上管	Upper thread column	1
5	201S16006	导线环螺母	Thread guide hook nut	4
6	21131009	导线架（短）	Thread spool tray bracket	1
7	20131018	过线环	Thread guide hook	6
8	20131021	棒架螺钉	Screw	3
9	21131010	棒架	Clamp plate	1
10	201S16004	螺母	Nut	4
11	20131022	棒架螺钉	Screw	1
12	201S16004	螺母	Nut	4
13	21131011	导线环	Thread guide hook	2
14	20131020	导线环螺钉	Screw	4
15	21131012	导线架（长）	Thread spool tray bracket	1
16	20131007	导线棒	Thread guide bar	1
17	20631019	过线棒	Thread guide	0
18	21131013	固定器	Thread guide joint	1
19	S04050	螺钉M5×15	Screw	2
20	21131014	套	Bushing	1
21	N01030	套螺母	Nut	2
22	21131015	线圈定位套	Spool Cushion	5
23	20131006	线托棒	Spool pin	5
24	20131010	线盘垫	Spool tray cushioning	5
25	21131016	线盘	Spool tray	5
26	21131017	托线架（长）	Thread spool tray bracket	1
27	201S16004	螺母	Nut	5
28	20128018	垫圈	Washer	5
29	21131018	下管	Lower thread column	1
30	201S16005	螺母	Nut	1
31	20128025	下管垫圈	Lower washer	2
32	21131019	托线架（短）	Thread spool tray bracket	1
33	20122049	防震垫	Plate dog link washer	2
34	20631020	过线棒	Thread guide	1
35	2113102700	线架组件	Thread stand component	1

17

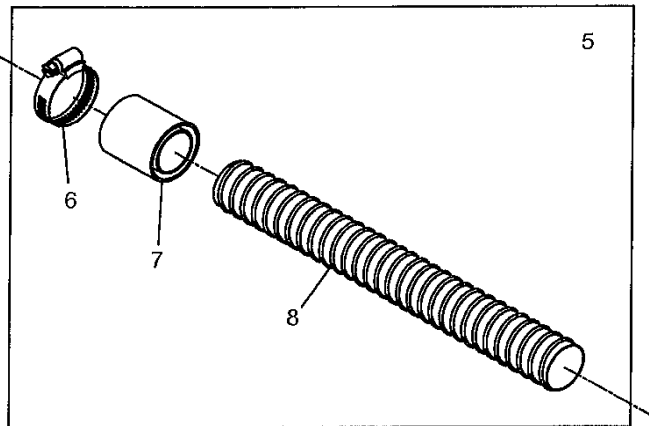
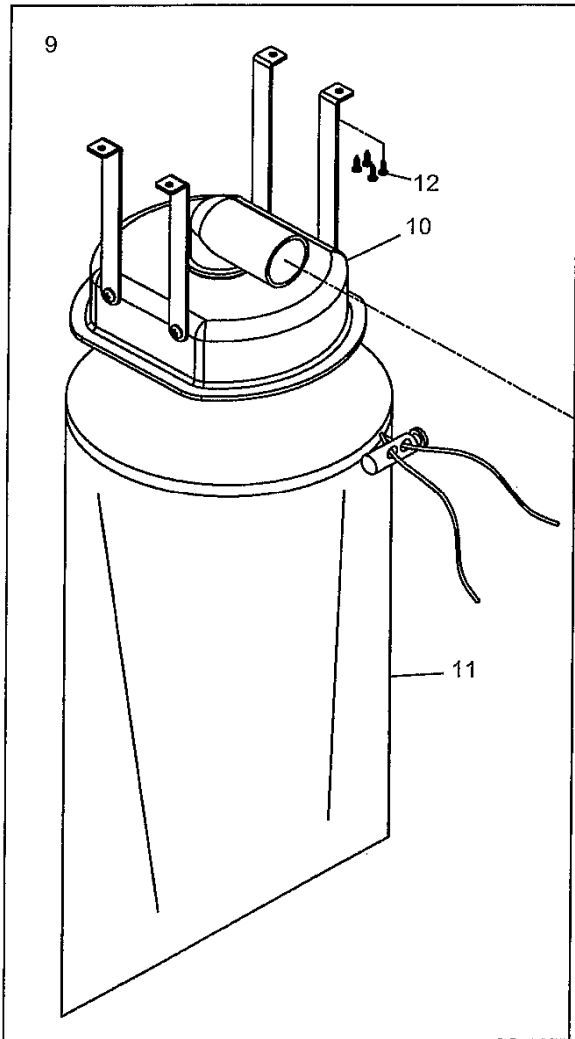
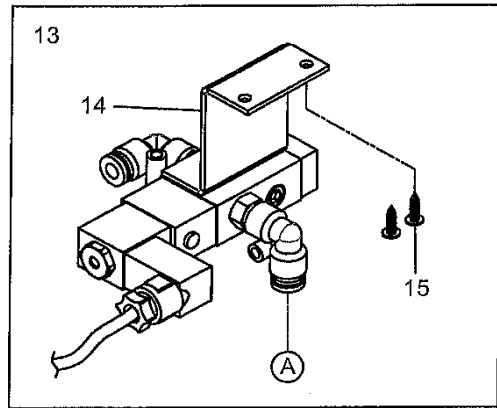
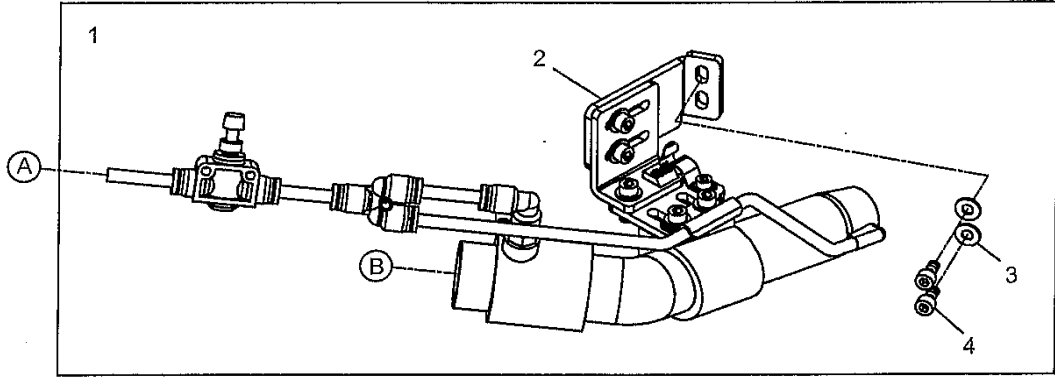

序号 Ref. N	公司件号 Parts. No	名称	Description	数量 Number
1	B17001	吸布管组件	Suction Pipe Unit, C. Set	1
2	B17002	吸布管	Suction Pipe Unit	1
3	B17003	垫片	Washer	2
4	C06043	螺钉	Screw (M5-0.8x10)	2
5	B17005	接管组件	Take Over, C. Set	1
6	B17006	管束	Hose Band	1
7	B17007	转接头	Take Over	1
8	B17008	螺旋管	Spiral Pipe	1
9	B17009	集布袋组件	Waste Gather System, C. Set	1
10	B17010	集布盖	Waste Gather Cover	1
11	B17011	集布袋	Waste Gather Bag	1
12	B17012	螺钉	Wood Screw	4
13	B17013	电磁阀组件	Solenoid Valve, C. Set	1
14	B17014	电磁阀组件	Solenoid Valve	1
15	B17015	螺钉	Wood Screw	2

18

01MS

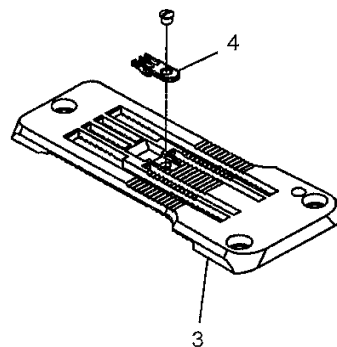
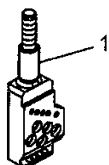
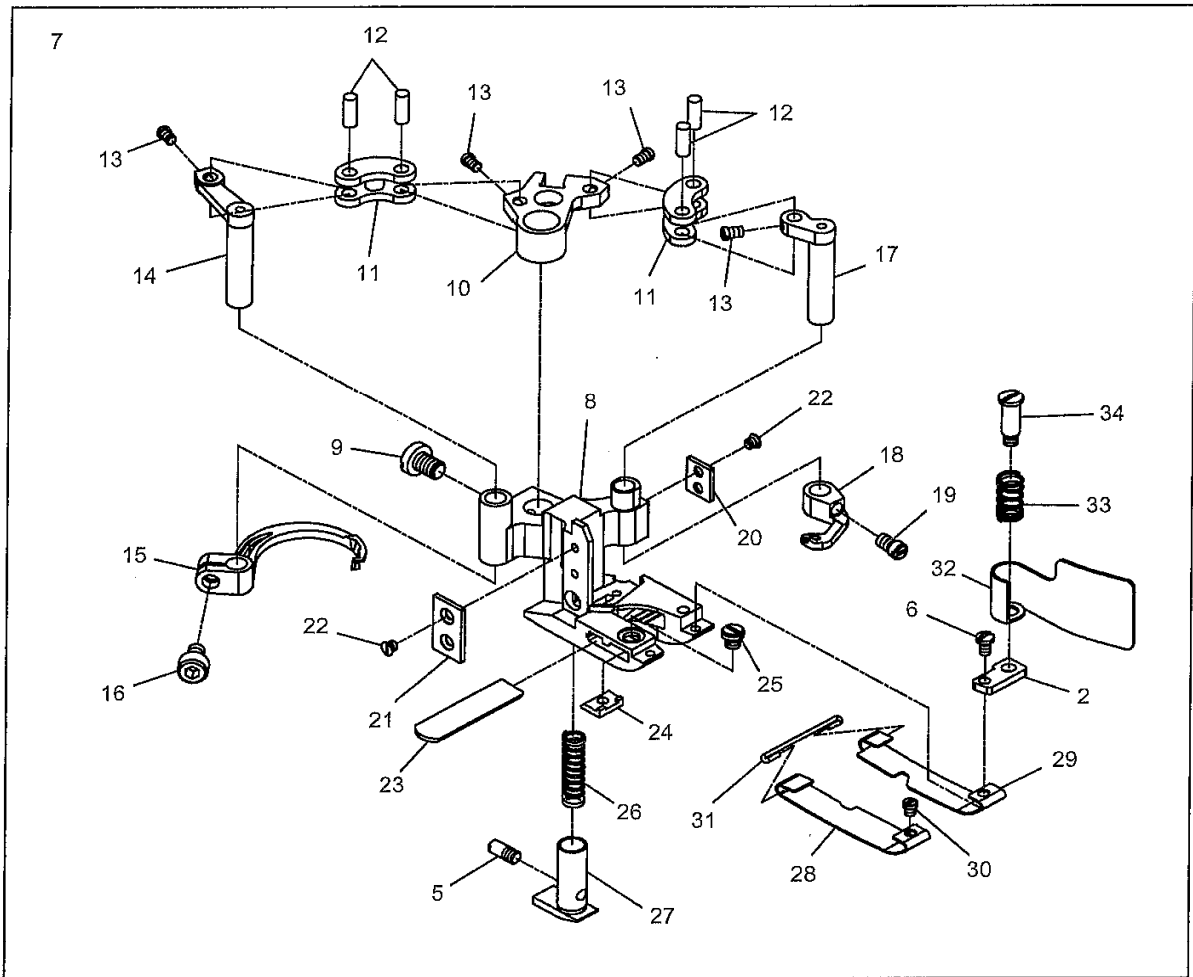

序号 Ref. N	公司件号 Parts. No	名称	Description	数量 Number
1	A0559	针舌	Needle Clamp	1
2	A0635	切角防护片座	Chip Guard Plate	1
3	A0560	针板	Stitch Plate	1
4	A0561	针板舌头	Stitch Plate Tongue	1
5	A0506	螺钉	Screw (1/8-44x5.3)	1
6	A0664	螺钉	Screw (3/32-56x4.3)	1
7	A0666	单切压脚组件	One Side Cut Presser Foot, C. Set	1
8	A0667	单切压脚	One Side Cut Presser Foot	1
9	A0616	螺钉	Screw (11/64-40x6.5)	1
10	A0617	喂针驱动扇形片	Carrier/Hook Driving Segment	1
11	A0618	喂针驱动连杆	Carrier/Hook Driving Lever Link	2
12	A0619	连杆销	Link Pin	4
13	A0620	螺钉	Screw (3/32-56x3.3)	4
14	A0621	喂针驱动横杆	Thread Hook Driving Lever	1
15	A0622	喂针线过线勾	Top Cover Thread Hook	1
16	A0623	螺钉	Screw (9/64-40x6)	1
17	A0624	喂针线托架驱动横杆	Top Cover Thread Carrier Driving Lever	1
18	A0669	喂针线托架	Top Cover Thread Carrier	1
19	A0626	螺钉	Screw (1/8-44x5)	1
20	A0627	压脚连接片(右)	Presser Foot Attach Piece (Right)	1
21	A0628	压脚连接片(左)	Presser Foot Attach Piece (Left)	1
22	A0629	螺钉	Screw (3/32-56x2.5)	4
23	A0630	下切刀	Lower Knife	1
24	A1218	下切刀夹板	Lower Knife Clamp	1
25	A0632	螺钉	Screw (1/8-44x3.4)	1
26	A0633	小压脚弹簧	Yielding Section Spring	1
27	A0634	小压脚	Yielding Section	1
28	A0636	压脚弹簧片(左)	Presser Foot Spring Plate (Left)	1
29	A0668	压脚弹簧片(右)	Presser Foot Spring Plate (Right)	1
30	A0638	螺钉	Screw (3/32-56x2.6)	1
31	A0639	弹簧片固定铁勾	Spring Plate Holder	1
32	A0640	切角防护片	Chip Guard	1
33	A0641	切角防护片弹簧	Chip Guard Spring	1
34	A0642	螺钉	Screw (1/8-44x3.4)	1

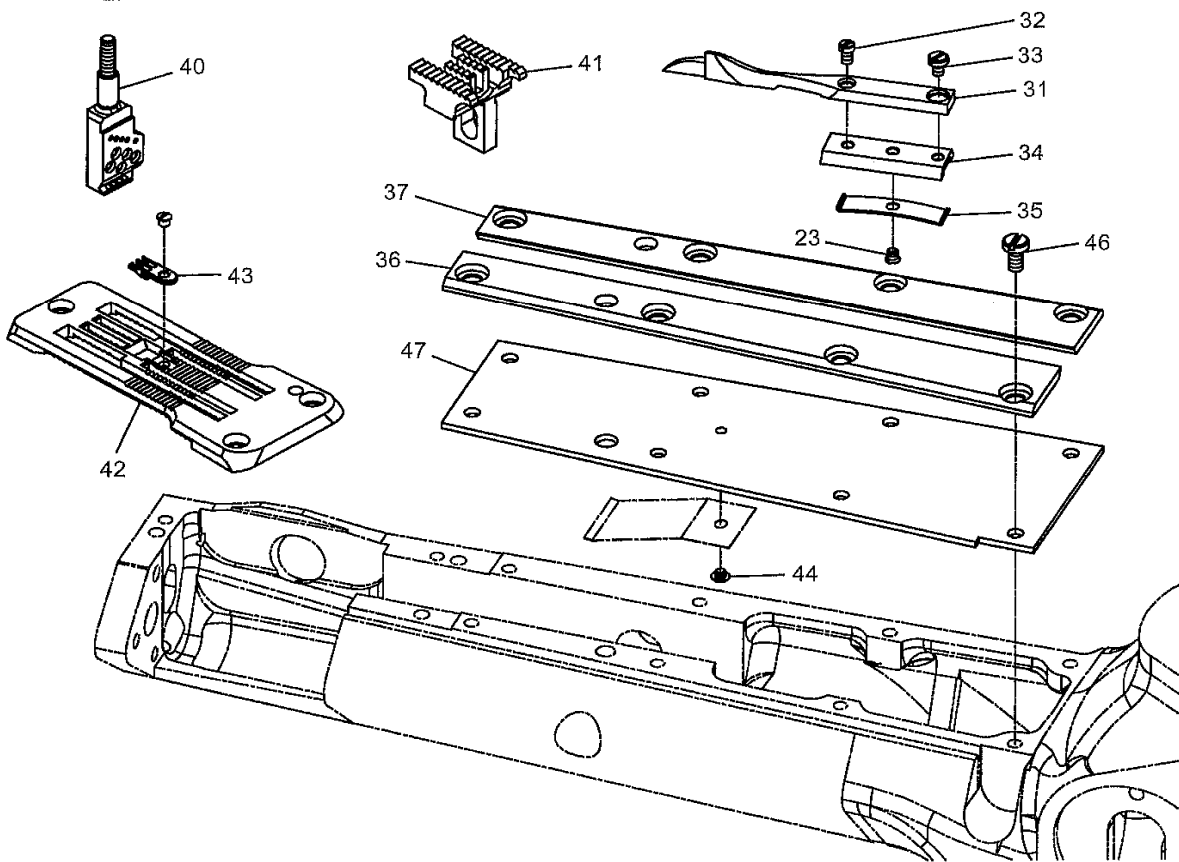
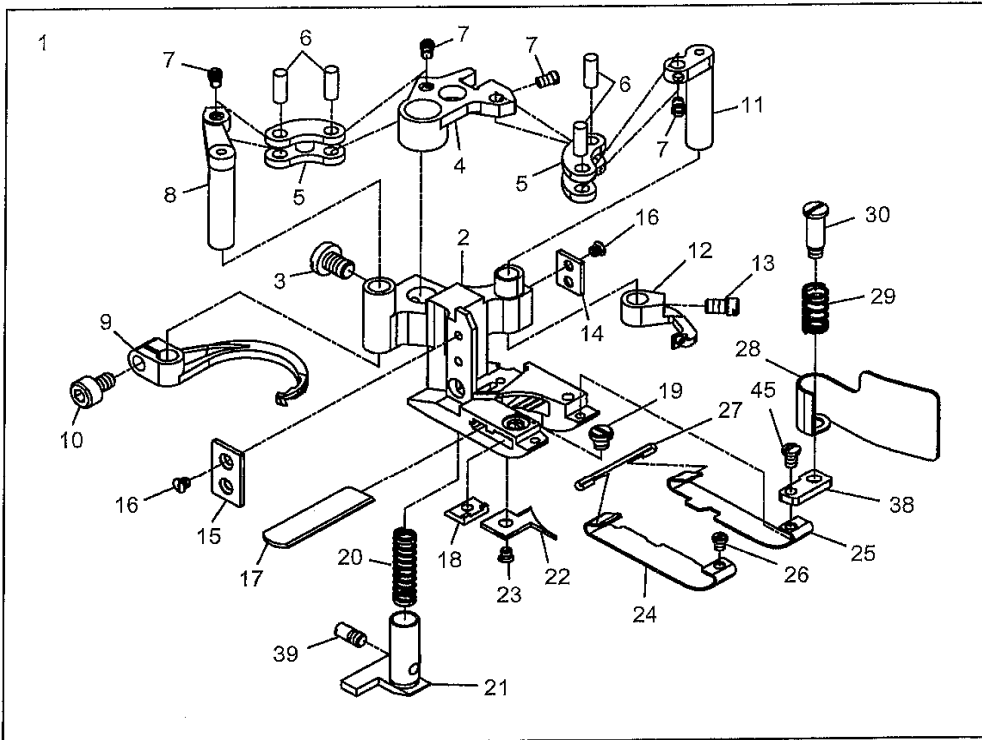

序号 Ref. N	公司件号 Parts. No	名称	Description	数量Number
1	A1257	双切压脚组件	Double Side Cut Presser Foot, C. Set	1
2	A1256	双切压脚	Double Side Cut Presser Foot	1
3	A0616	螺钉	Screw (11/64-40x6.5)	1
4	A0617	喂针驱动扇形片	Carrier/Hook Driving Segment	1
5	A0618	喂针驱动连杆	Carrier/Hook Driving Lever Link	2
6	A0619	连杆销	Link Pin	4
7	A0620	螺钉	Screw (3/32-56x3,4)	4
8	A0621	喂针驱动横杆	Thread Hook Driving Lever	1
9	A0622	喂针线过线勾	Top Cover Thread Hook	1
10	A0623	螺钉	Screw (9/64-40x6.4)	1
11	A0624	喂针线托架驱动横杆	Top Cover Thread Carrier Driving Lever	1
12	A0669	喂针线过线勾	Top Cover Thread Carrier	1
13	A0626	螺钉	Screw (1/8-44x5)	1
14	A0627	压脚连接片(右)	Presser Foot Attach Piece (Right)	1
15	A0628	压脚连接片(左)	Presser Foot Attach Piece (Left)	1
16	A0629	螺钉	Screw (3/32-56x2.5)	4
17	A0630	下切刀	Lower Knife	1
18	A1218	下切刀夹片	Lower Knife Clamp	1
19	A0632	螺钉	Screw (1/8-44x3.4)	1
20	A0633	小压脚弹簧	Yielding Section Spring	1
21	A1221	小压脚	Yielding Section	1
22	A1222	压脚舌头	Presser Foot Tongue	1
23	A1223	螺钉	Screw (3/32-56x2.8)	2
24	B12124	压脚弹簧片(左)	Presser Foot Spring Plate (Left)	1
25	B12125	压脚弹簧片(右)	Presser Foot Spring Plate (Right)	1
26	A0638	螺钉	Screw (3/32-56x2.6)	1
27	A0639	弹簧片固定座	Spring Plate Holder	1
28	A1228	切角防护片	Chip Guard	1
29	A0641	切角防护片弹簧	Chip Guard Spring	1
30	A0642	螺钉	Screw (1/8-44x3.4)	1
31	A1231	前导布器(薄料用)	Lap Former	1
32	A1232	螺钉	Screw (3/32-56x3.8)	1
33	A1233	螺钉	Screw (3/32-56x3.8)	1
34	A1234	前导布器滑块	Lap Former Slide Block	1
35	A1235	前导布器滑块弹簧片	Lap Former Slide Block Spring	1
36	A1236	前导布器导轨(左)	Lap Former Guide Plate (Left)	1
37	A1237	前导布器导轨(右)	Lap Former Guide Plate (Right)	1
38	A0635	切角防护片座	Chip Guard Plate	1
39	A0506	螺钉	Screw (1/8-44x5.3)	1
40	A0559	针古	Needle Clamp	1
41	A1241	主送齿	Main Feed Dog	1
42	A1255	针板	Stitch Plate	1
43	A0561	针板舌头	Stitch Plate Tongue	1
44	A0220	螺钉	Screw (3/32-56x2.1)	1
45	A0664	螺钉	Screw (3/32-56x4.3)	1
46	A0218	螺钉	Screw (1/8-44x6.5)	8
47	A1239	下巴盖板	Sewing Cylinder Cover (Upper)	1

20

12HS

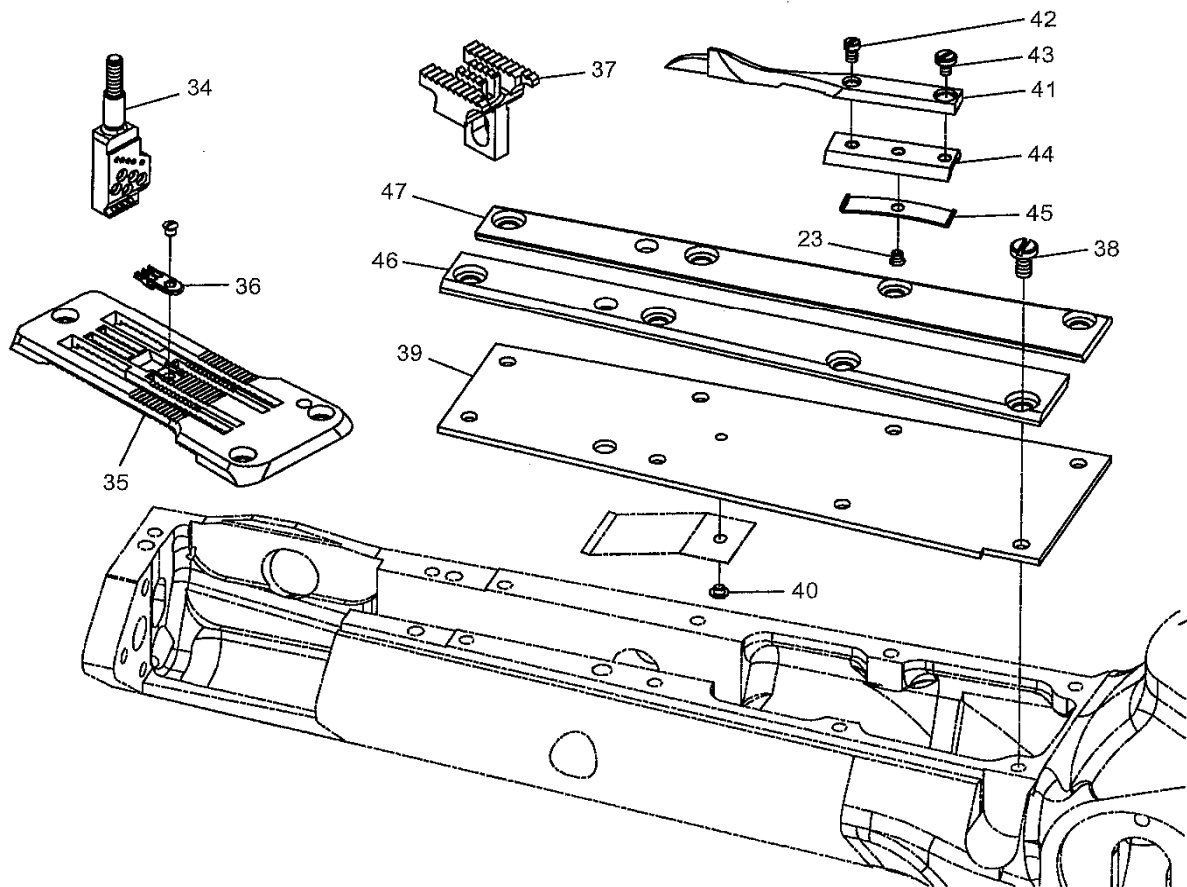
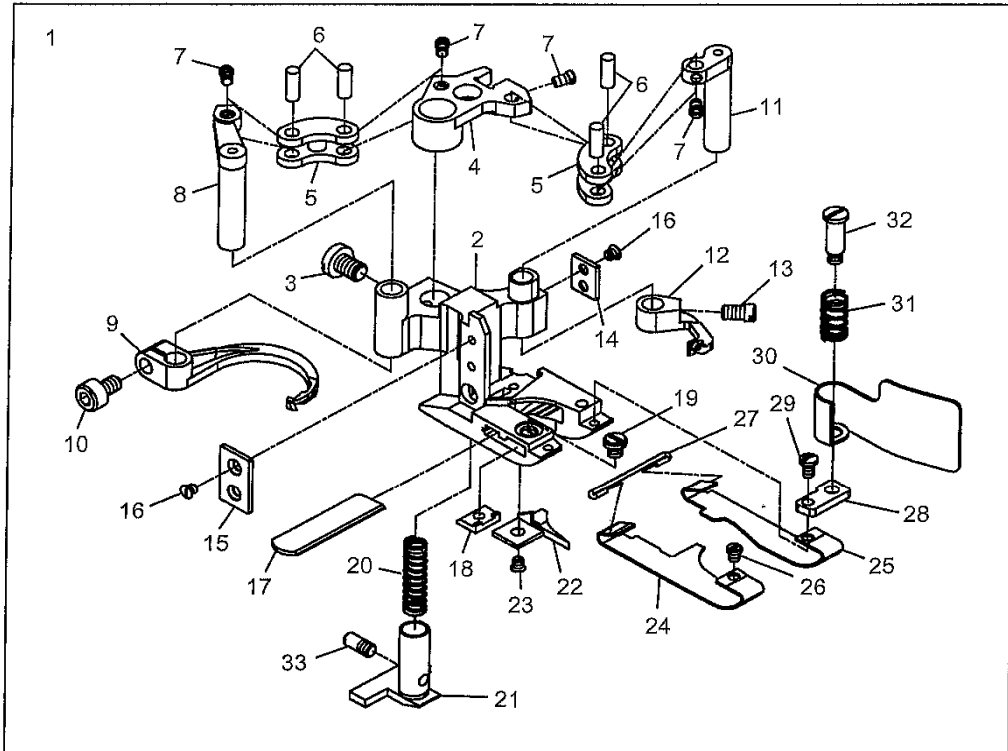

序号 Ref. N	公司件号 Parts. No	名称	Description	数量 Number
1	B6012H	双切压脚组件	Double Side Cut Presser Foot, C. Set	1
2	B1902	双切压脚	Double Side Cut Presser Foot	1
3	A0616	螺钉	Screw (11/64-40x6.5)	1
4	A0617	喂针驱动扇形片	Carrier/Hook Driving Segment	1
5	A0618	喂针驱动连杆	Carrier/Hook Driving Lever Link	2
6	A0619	连杆销	Link Pin	4
7	A0620	螺钉	Screw (3/32-56x3.4)	4
8	A0621	喂针驱动横杆	Thread Hook Driving Lever	1
9	A0622	喂针线过线勾	Top Cover Thread Hook	1
10	A0623	螺钉	Screw (9/64-40x6,4)	1
11	A0624	喂针线托架驱动横杆	Top Cover Thread Carrier Driving Lever	1
12	A0669	喂针线过线勾	Top Cover Thread Carrier	1
13	A0626	螺钉	Screw (1/8-44x5)	1
14	A0627	压脚连接片(右)	Presser Foot Attach Piece (Right)	1
15	A0628	压脚连接片(左)	Presser Foot Attach Piece (Left)	1
16	A0629	螺钉	Screw (3/32-56x2.5)	4
17	B1917	下切刀	Lower Knife	1
18	A1218	下切刀夹片	Lower Knife Ciamp	1
19	A0632	螺钉	Screw (1/8-44x3.4)	1
20	A0633	小压脚弹簧	Yielding Section Spring	1
21	A1221	小压脚	Yielding Section	1
22	B1922	压脚舌头	Presser Foot Tongue	1
23	A1223	螺钉	Screw (3/32-56x2.8)	2
24	B1924	压脚弹簧片(左)	Presser Foot Spring Plate (Left)	1
25	B1925	压脚弹簧片(右)	Presser Foot Spring Plate (Right)	1
26	A0638	螺钉	Screw (3/32-56x2.6)	1
27	A0639	弹簧片固定座	Spring Plate Holder	1
28	A0635	切角防护片座	Chip Guard Plate	1
29	A0664	螺钉	Screw (3/32-56x43)	1
30	A1228	切角防护片	Chip Guard	1
31	A0641	切角防护片弹簧	Chip Guard Spring	1
32	A0642	螺钉	Screw (1/8-44x3.4)	1
33	A0506	螺钉	Screw (1/8-44x5.3)	1
34	A0559	针舌	Needle Clamp	1
35	A1255	针板	Stitch Plate	1
36	A0561	针板舌头	Stitch Plate Tongue	1
37	A1241	主送齿	Main Feed Dog	1
38	A0218	螺钉	Screw (1/8-44x6.5)	8
39	A1239	下巴盖板	Sewing Cylinder Cover (Upper)	1
40	A0220	螺钉	Screw (3/32-56x2.1)	1
41	B1933	前导布器(厚料用)	Lap Former	1
42	A1232	螺钉	Screw (3/32-56x3.8)	1
43	A1233	螺钉	Screw (3/32-56x3.8)	1
44	A1234	前导布器滑块	Lap Former Slide Block	1
45	A1235	前导布器滑块弹簧片	Lap Former Slide Block Spring	1
46	A1236	前导布器导轨(左)	Lap Former Guide Plate (Left)	1
47	A1237	前导布器导轨(右)	Lap Former Guide Plate (Right)	1

21

12HS

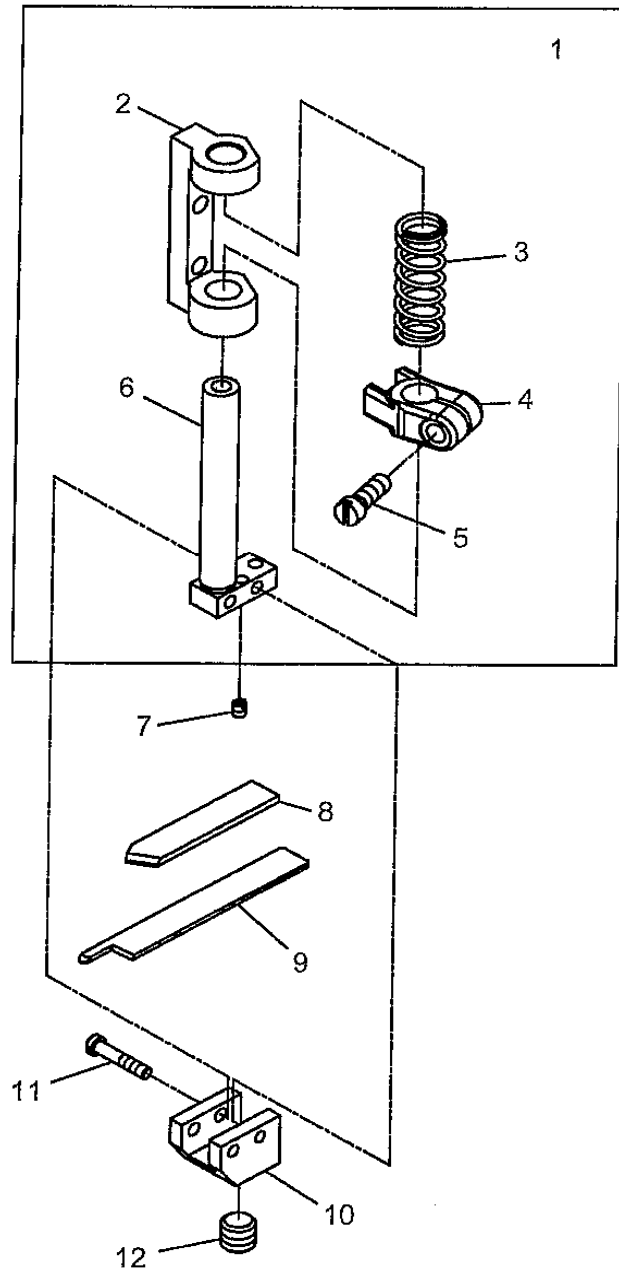

序号 Ref. N	公司件号 Parts. No	名称	Description	数量 Number
1	B2101	活动刀组件	Knife Holder Guide Collar, C. Set	1
2	A0733	上切刀固定座支架	Knife Holder Shank Support	1
3	A0734	上切刀固定座弹簧	Knife Holder Spring	1
4	A0735	上切刀弹簧固定座	Knife Holder Guide Collar	1
5	A0736	螺钉	Screw (9/64-40x10.4)	1
6	B2106	上切刀固定座柄	Knife Holder Shank	1
7	A0739	螺钉	Screw (3/32-56x3.8)	1
8	B2108	上切刀支架	Knife Support	1
9	B2109	上切刀	Upper Knife	1
10	B2110	上切刀固定座	Knife Holder	1
11	B2111	螺钉	Screw (3/32-56x7)	2
12	A0745	螺钉	Screw (1/4-40x6)	1

01HR

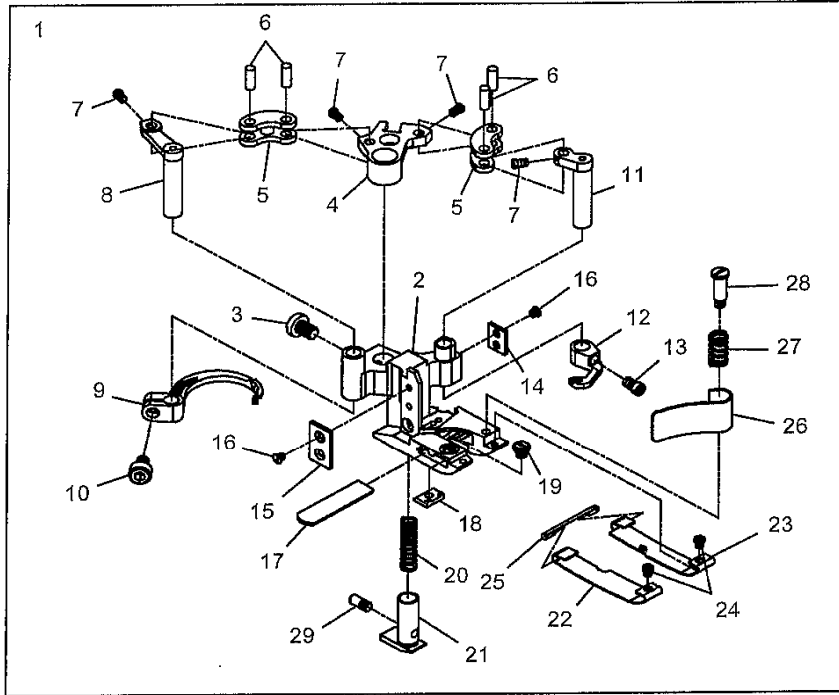

01HS

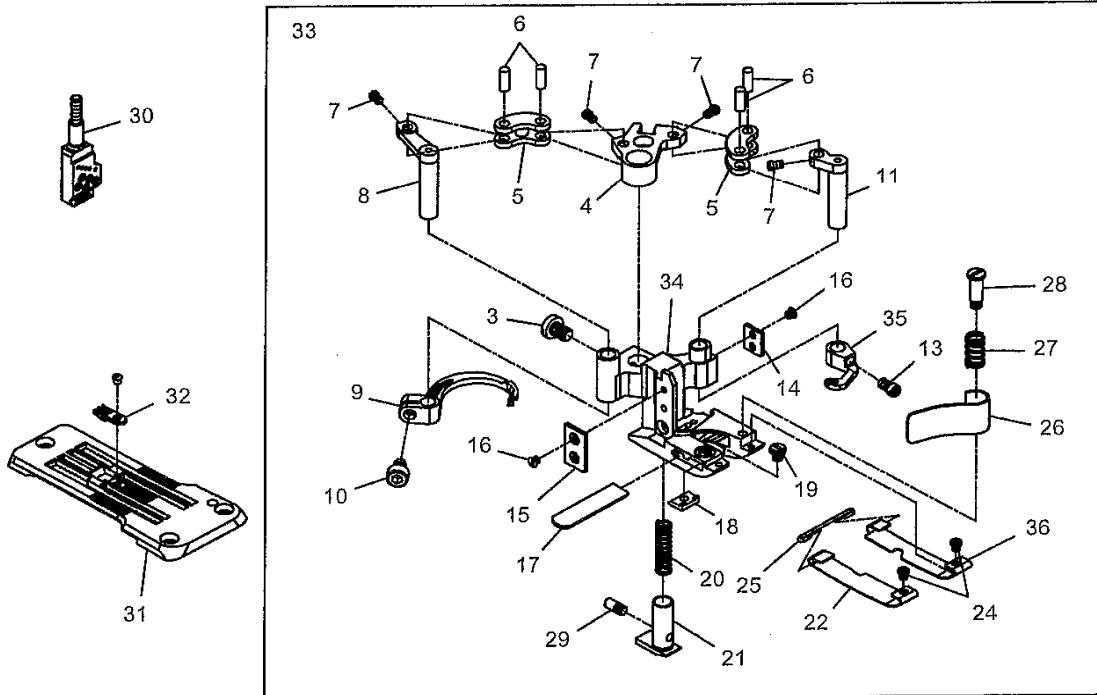

序号 Ref. N	公司件号 Parts. No	名称	Description	数量Number
1	B2205	单切压脚组件	One Side Cut Presser Foot, C. Set	1
2	B2202	单切压脚	One Side Cut Presser Foot	1
3	A0616	螺钉	Screw (11/64-40x6.5)	1
4	A0617	喂针驱动扇形片	Carrier/Hook Driving Segment	1
5	A0618	喂针驱动连杆	Carrier/Hook Driving Lever Link	2
6	A0619	连杆销	Link Pin	4
7	A0620	螺钉	Screw (3/32-56x3.3)	4
8	A0621	喂针驱动横杆	Thread Hook Driving Lever	1
9	A0622	喂针线过线勾	Top Cover Thread Hook	1
10	A0623	螺钉	Screw (9/64-40x6)	1
11	A0624	喂针线托架驱动横杆	Top Cover Thread Carrier Driving Lever	1
12	A0625	喂针线托架	Top Cover Thread Carrier	1
13	A0626	螺钉	Screw (1/8-44x5)	1
14	A0627	压脚连接片(右)	Presser Foot Attach Piece (Right)	1
15	A0628	压脚连接片(左)	Presser Foot Attach Piece (Left)	1
16	A0629	螺钉	Screw (3/32-56x2.5)	4
17	A0630	下切刀	Lower Knife	1
18	A1218	下切刀夹片	Lower Knife Clamp	1
19	A0632	螺钉	Screw (1/8-44x3.4)	1
20	A0633	小压脚弹簧	Yielding Section Spring	1
21	A0634	小压脚	Yielding Section	1
22	A0636	压脚弹簧片(左)	Presser Foot Spring Plate (Left)	1
23	A0668	压脚弹簧片(右)	Presser Foot Spring Plate (Right)	1
24	A0638	螺钉	Screw (3/32-56x2,6)	1
25	A0639	弹簧片固定铁勾	Spring Plate Holder	1
26	A0640	切角防护片	Chip Guard	1
27	A0641	切角防护片弹簧	Chip Guard Spring	1
28	A0642	螺钉	Screw (1/8-44x3.4)	1
29	A0506	螺钉	Screw (1/8-44x5.3)	1
30	A0559	针古	Needle Clamp	1
31	A0560	针板	Stitch Plate	1
32	A0561	针板舌头	Stitch Plate Tongue	1
33	B2305	单切压脚组件	One Side Cut Presser Foot, C. Set	1
34	B2234	单切压脚	One Side Cut Presser Foot	1
35	A0669	喂针线托架	Top Cover Thread Carrier	1
36	A0668	压脚弹簧片(右)	Presser Foot Spring Plate (Right)	1

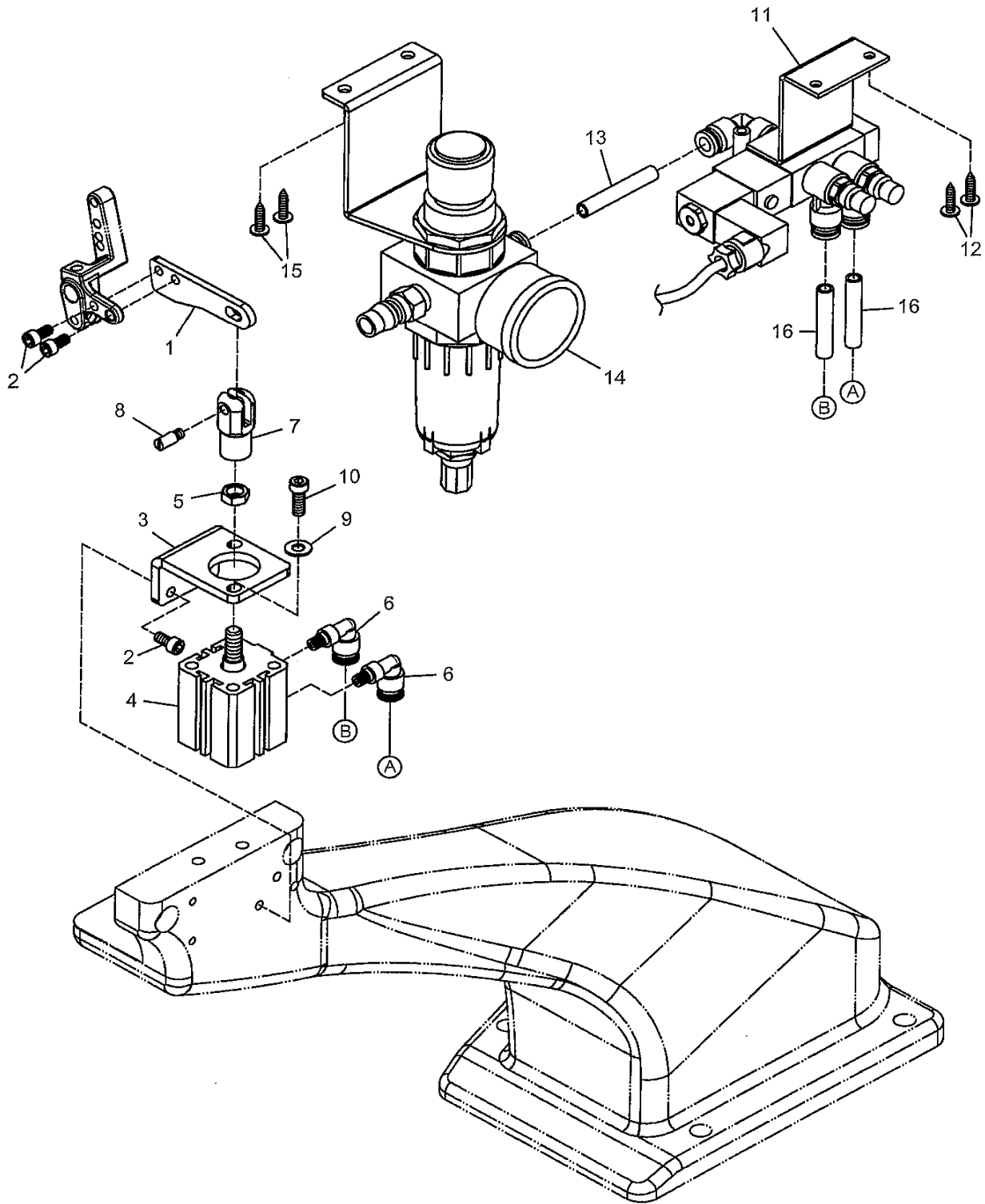

序号 Ref. N	公司件号 Parts. No	名称	Description	数量 Number
1	B2536	抬压脚连杆	Presser Bar Lifter Lever	1
2	B1402	螺钉	Screw (M5-0.8x10)	5
3	B2537	气缸支架	Cylinder Support Plate	1
4	B23104	气缸	Cylinder	1
5	B23105	螺母	Nut	1
6	B23106	接头	Air Tube Joint	2
7	B1420	Y型接头	"Y" Joint	1
8	B1410	螺钉	Screw (M5-0.8x5)	1
9	B2522	垫片	Washer	2
10	B2566	螺钉	Screw (M6-1x20)	2
11	B23113	电磁阀	Solenoid Valve	1
12	B17015	螺钉	Wood Screw	2
13	B23015	PU管	Air Tube (4x6x250mm)	1
14	B23016	调压过滤器	Filter Regulator	1
15	B23017	螺钉	Wood Screw	2
16	B23018	PU管	Air Tube (4x6x900mm)	2

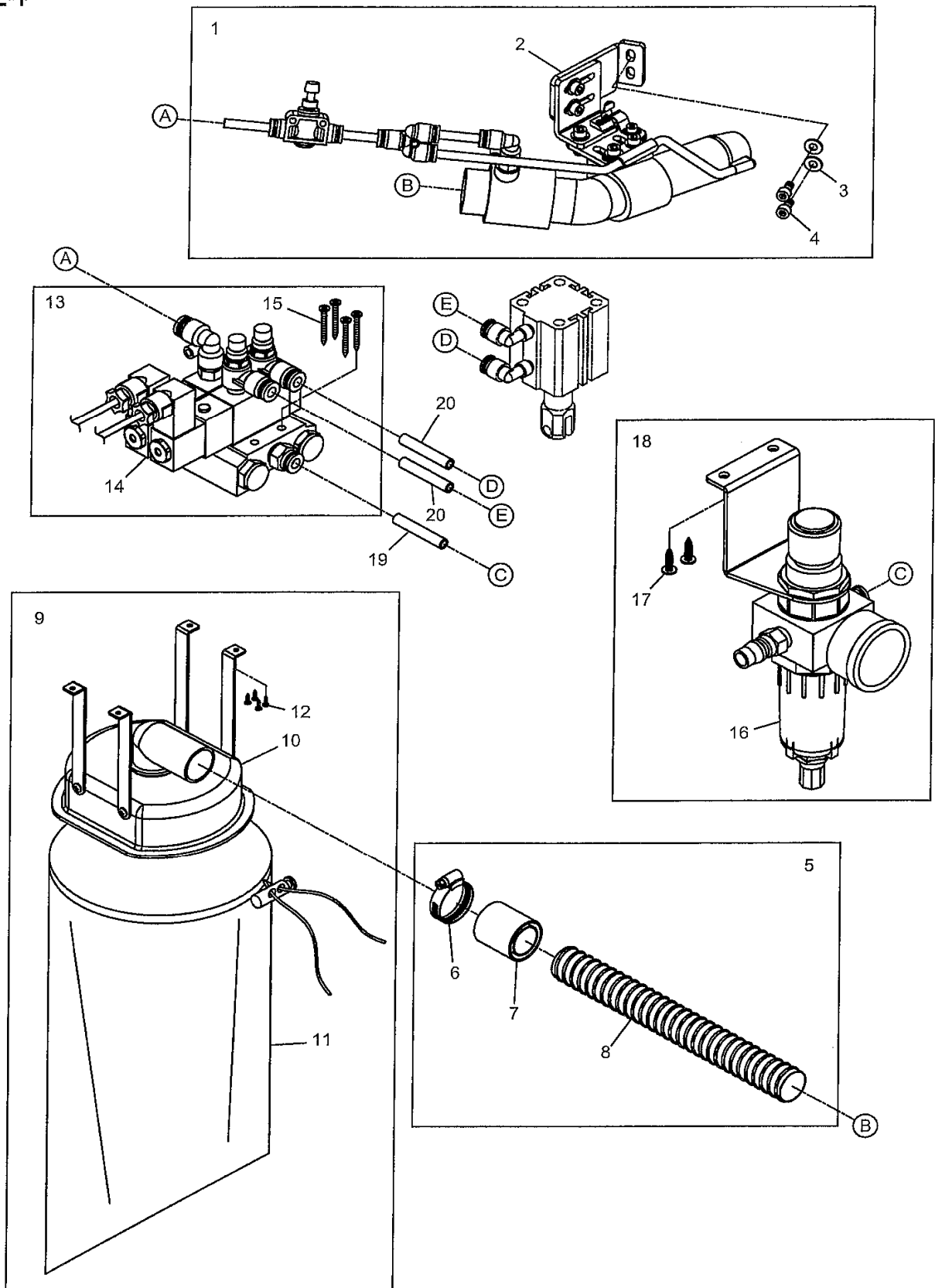

序号 Ref. N	公司件号 Parts. No	名称	Description	数量 Number
1	B17001	吸布管组件	Suction Pipe Unit, C. Set	1
2	B17002	吸布管	Suction Pipe Unit	1
3	B17003	垫片	Washer	2
4	C06043	螺钉	Screw (I\15-0.8x10)	2
5	B17005	接管组件	Take Over, C. Set	1
6	B17006	管束	Hose Band	1
7	B17007	转接头	Take Over	1
8	B17008	旋转管	Spiral Pipe	1
9	B17009	集布袋组件	Waste Gather System, C. Set	1
10	B17010	集布盖	Waste Gather Cover	1
11	B17011	集布袋	Waste Gather Bag	1
12	B17012	螺钉	Wood Screw	4
13	B17013	电磁阀组件	Solenoid Valve, C. Set	1
14	B17014	电磁阀	Solenoid Valve	1
15	B17015	螺钉	Wood Screw	2
16	B23016	调压过滤器	Filter Regulator	[
17	B23017	螺钉	Wood Screw	2
18	B24016	调压过滤器组件	Filter Regulator, C. Set	1
19	B23015	PU管	Air Tube (4x6x250mm)	1
20	B23018	PU管	Air Tube (4x6x900mm)	2

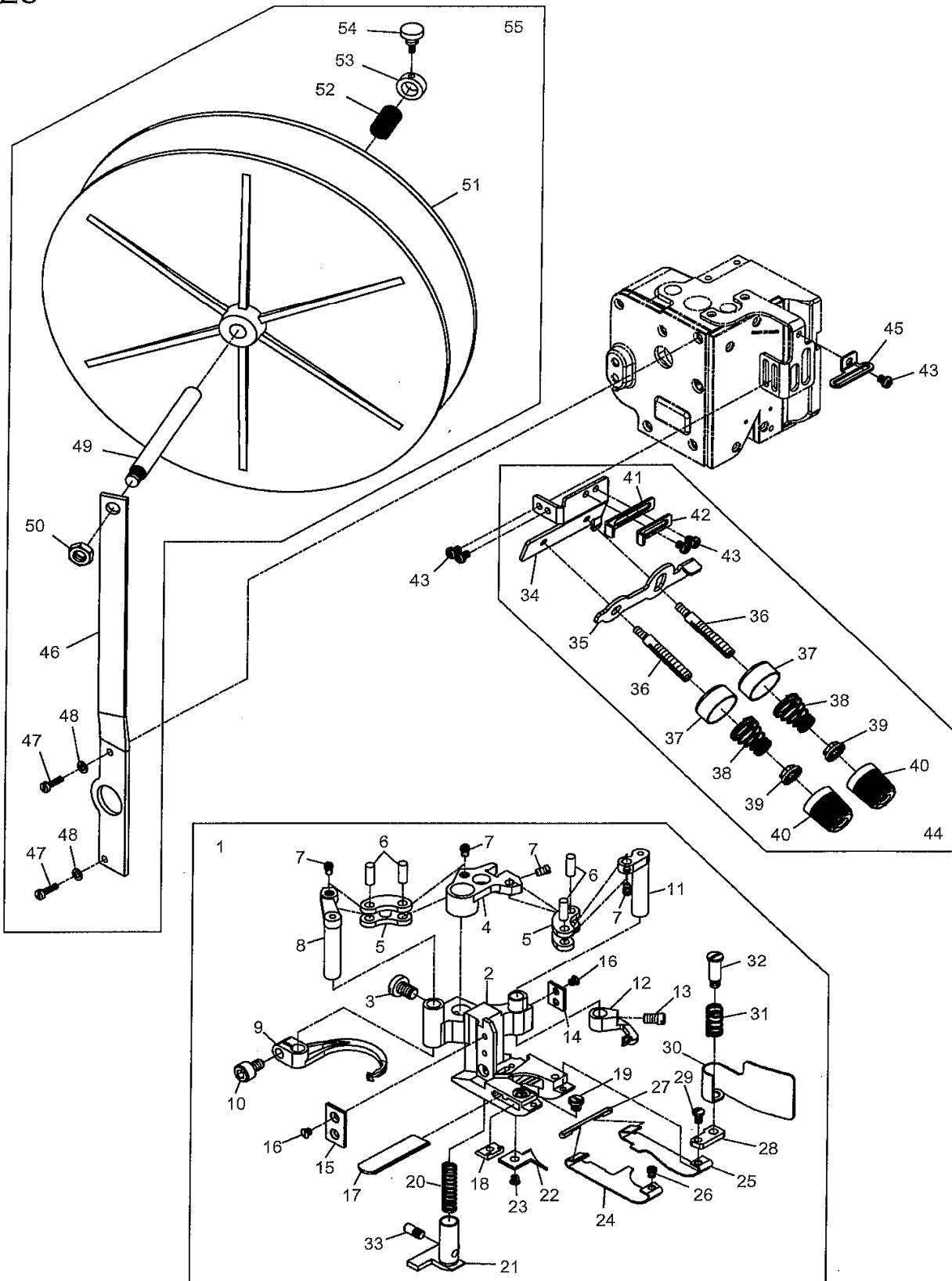

序号 Ref. N	公司件号 Parts. No	名称	Description	数量Number
1	B25001	双切压脚组件	Double Side Cut Presser Foot, C. Set	1
2	B25002	双切压脚	Double Side Cut Presser Foot	1
3	A0616	螺钉	Screw (11/64-40x6.5)	1
4	A0617	喂针驱动扇形片	Carrier/Hook Driving Segment	1
5	A0618	喂针驱动连杆	Carrier/Hook Driving Lever Link	2
6	A0619	连杆销	Link Pin	4
7	A0620	螺钉	Screw (3/32-56x3.3)	4
8	A0621	喂针驱动横杆	Thread Hook Driving Lever	1
9	A0622	喂针线过线勾	Top Cover Thread Hook	1
10	A0623	螺钉	Screw (9/64-40x6)	1
11	A0624	喂针线托架驱动横杆	Top Cover Thread Carrier Driving Lever	1
12	A0625	喂针线托架	Top Cover Thread Carrier	1
13	A0626	螺钉	Screw (1/8-44x5)	1
14	A0627	压脚连接片(右)	Presser Foot Attach Piece (Right)	1
15	A0628	压脚连接片(左)	Presser Foot Attach Piece (Left)	1
16	A0629	螺钉	Screw (3/32-56x2.5)	4
17	B1917	下切刀	Lower Knife	1
18	A1218	下切刀夹板	Lower Knife Clamp	1
19	A0632	螺钉	Screw (1/8-44x3.4)	1
20	A0633	小压脚弹簧	Yielding Section Spring	1
21	A1221	小压脚	Yielding Section	1
22	A1222	压脚舌头	Presser Foot Tongue	1
23	A1223	螺钉	Screw (3/32-56x2.8)	1
24	A1259	压脚弹簧片(左)	Presser Foot Spring Plate (Left)	1
25	A1225	压脚弹簧片(右)	Presser Foot Spring Plate (Right)	1
26	A0638	螺钉	Screw (3/32-56x2.6)	1
27	A0639	弹簧片固定铁钩	Spring Plate Holder	1
28	A0635	切角防护片座	Chip Guard Plate	1
29	A0664	螺钉	Screw (3/32-56x4.3)	1
30	A1228	切角防护片	Chip Guard	1
31	A0641	切角防护片弹簧	Chip Guard Spring	1
32	A0642	螺钉	Screw (1/8-44x3.4)	1
33	A0506	螺钉	Screw (1/8-44x5.3)	1
34	B25034	固定板	Guide	1
35	B25035	夹布片	Tension Dist	2
36	B25036	螺柱	Screw Stud	2
37	C03005	上线张力弹簧固定座	Thread Tension Spring Retainer	2
38	C03003	机针线张力弹簧	Tension Spring(Needle)	2
39	C03002	张力弹簧套管	Tension Spring Bushing	2
40	C03001	上线张力弹簧调整螺母	Thread Tension Spring Cap	2
41	B25041	过布片	Tape Guide	1
42	B25042	过布片	Tape Guide	1
43	C02044	螺钉	Screw (M4-0.7x5)	5
44	B25044	夹布片组件	Tension Dist Assembly	1
45	B25045	过布片	Tape Guide	1
46	B25046	支撑架	Tape Reel Support	1
47	B25047	螺钉	Screw (9/64-40x12)	2
48	B25048	垫片	Washer	2
49	B25049	支撑杆	Tape Reel Shaft	1
50	B25050	螺母	Nut	1
51	B25051	塑料盘	Tape Base	2
52	B25052	弹簧	Spring	1
53	B25053	轴环	Collar	1
54	C16005	螺钉	Screw	1
55	B25055	塑料盘组件	Tape Base, C. Set	1

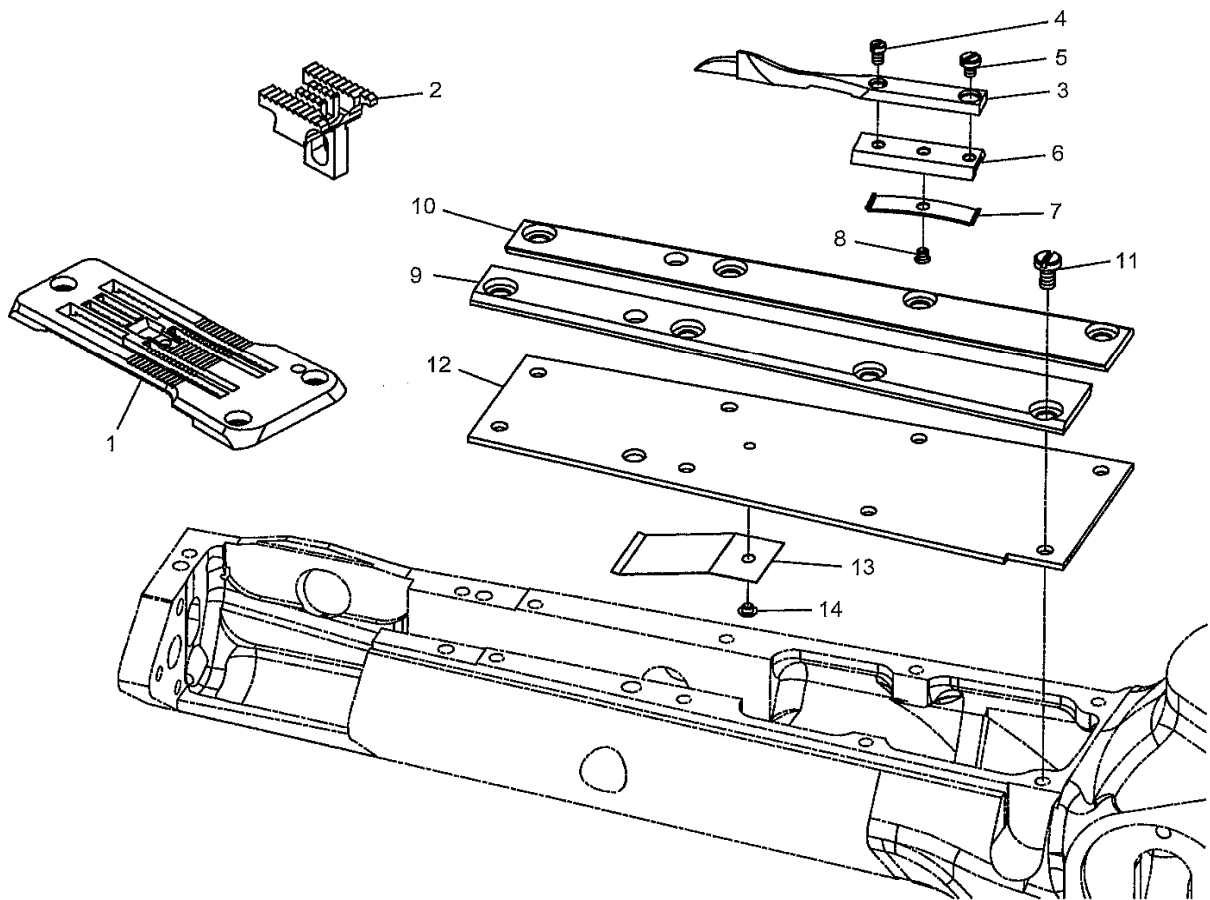

序号 Ref. N	公司件号 Parts. No	名称	Description	数量 Number
1	A1255	针板	Stitch Plate	1
2	A1241	主送齿	Main Feed Dog	1
3	A1231	前导布器(薄料用)	Lap Former	1
4	A1232	螺钉	Screw (3/32-56x3.8)	1
5	A1233	螺钉	Screw (3/32-56x3.8)	1
6	A1234	前导布器滑块	Lap Former Slide Block	1
7	A1235	前导布器滑块弹簧片	Lap Former Slide Block Spring	1
8	A1223	螺钉	Screw (3/32-56x2.8)	1
9	A1236	前导布器导轨(左)	Lap Former Guide Plate (Left)	1
10	A1237	前导布器导轨(右)	Lap Former Guide Plate (Right)	1
11	A0218	螺钉	Screw (1/8-44x6.5)	1
12	A1239	下巴盖板	Sewing Cylinder Cover (Upper)	1
13	A0219	防尘盖(上)	Dust Defender (Upper)	1
14	A0220	螺钉	Screw (3/32-56x2.1)	1

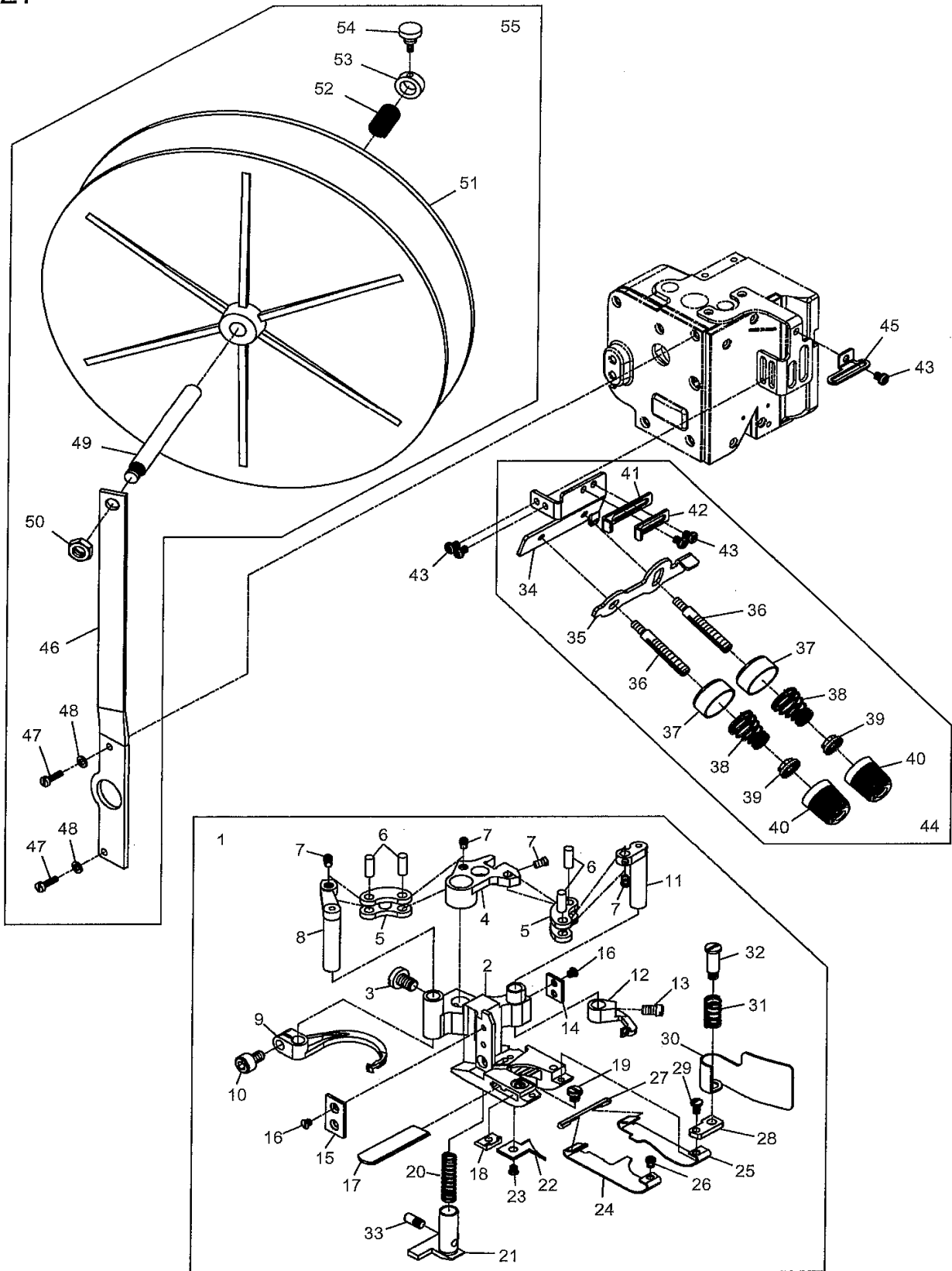



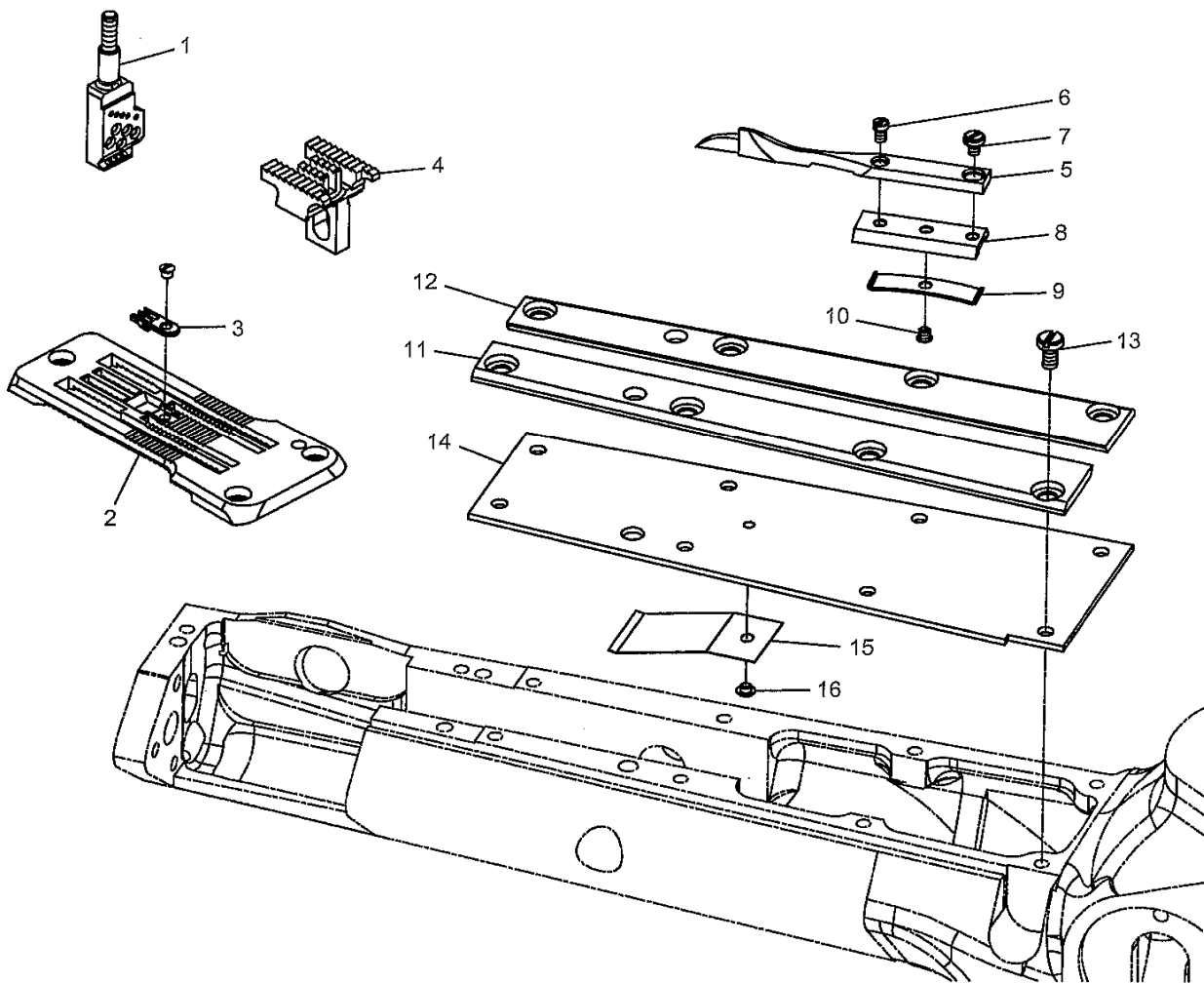







序号 Ref. N	公司件号 Parts. No	名称	Description	数量Number
1	B27001	双切压脚组件	Double Side Cut Presser Foot, C. Set	1
2	B27002	双切压脚	Double Side Cut Presser Foot	1
3	A0616	螺钉	Screw (11/64-40x6.5)	1
4	A0617	喂针驱动扇形片	Carrier/Hook Driving Segment	1
5	A0618	喂针驱动连杆	Carrier/Hook Driving Lever Link	2
6	A0619	连杆销	Link Pin	4
7	A0620	螺钉	Screw (3/32-56x3.3)	4
8	A0621	喂针驱动横杆	Thread Hook Driving Lever	1
9	A0622	喂针线过线勾	Top Cover Thread Hook	1
10	A0623	螺钉	Screw (9/64-40x6)	1
11	A0624	喂针线托架驱动横杆	Top Cover Thread Carrier Driving Lever	1
12	A0625	喂针线托架	Top Cover Thread Carrier	1
13	A0626	螺钉	Screw (1/8-44x5)	1
14	A0627	压脚连接片(右)	Presser Foot Attach Piece (Right)	1
15	A0628	压脚连接片(左)	Presser Foot Attach Piece (Left)	1
16	A0629	螺钉	Screw (3/32-56x2.5)	4
17	B1917	下切刀	Lower Knife	1
18	A1218	下切刀夹板	Lower Knife Clamp	1
19	A0632	螺钉	Screw (1/8-44x3.4)	1
20	A0633	小压脚弹簧	Yielding Section Spring	1
21	A1221	小压脚	Yielding Section	1
22	A1222	压脚舌头	Presser Foot Tongue	1
23	A1223	螺钉	Screw (3/32-56x2.8)	1
24	A1259	压脚弹簧片(左)	Presser Foot Spring Plate (Left)	1
25	A1225	压脚弹簧片(右)	Presser Foot Spring Plate (Right)	1
26	A0638	螺钉	Screw (3/32-56x2.6)	1
27	A0639	弹簧片固定铁钩	Spring Plate Holder	1
28	A0635	切角防护片座	Chip Guard Plate	1
29	A0664	螺钉	Screw (3/32-56x4.3)	1
30	A1228	切角防护片	Chip Guard	1
31	A0641	切角防护片弹簧	Chip Guard Spring	1
32	A0642	螺钉	Screw (1/8-44x3.4)	1
33	A0506	螺钉	Screw (1/8-44x5.3)	1
34	B25034	固定板	Guide	1
35	B25035	夹布片	Tension Dist	2
36	B25036	螺杆	Screw Stud	2
37	C03005	上线张力弹簧固定座	Thread Tension Spring Retainer	2
38	C03003	机针线张力弹簧	Tension Spring(Needle)	2
39	C03002	张力弹簧套管	Tension Spring Bushing	2
40	C03001	上线张力弹簧调整螺母	Thread Tension Spring Cap	2
41	B25041	压布片	Tape Guide	1
42	B25042	过布片	Tape Guide	1
43	C02044	螺钉	Screw (M4-0.7x5)	5
44	B25044	夹布片组件	Tension Dist Assembly	1
45	B25045	过布片	Tape Guide	1
46	B25046	支撑架	Tape Reel Support	1
47	B25047	螺钉	Screw (9/64-40x12)	2
48	B25048	垫片	Washer	2
49	B25049	支撑杆	Tape Reel Shaft	1
50	B25050	螺母	Nut	1
51	B25051	塑料盘	Tape Base	2
52	B25052	弹簧	Spring	1
53	B25053	轴环	Collar	1
54	C16005	螺钉	Screw	1
55	B25055	塑料盘组件	Tape Base, C. Set	1



序号 Ref. N	公司件号 Parts. No	名称	Description	数量 Number
1	A0559	针古	Needle Clamp	1
2	A1255	针板	Stitch Plate	1
3	A0561	针板舌头	Stitch Plate Tongue	1
4	A1241	主送齿	Main Feed Dog	1
5	A1231	前导布器(薄料用)	Lap Former	1
6	A1232	螺钉	Screw (3/32-56x3.8)	1
7	A1233	螺钉	Screw (3/32-56x3.8)	1
8	A1234	前导布器滑块	Lap Former Slide Block	1
9	A1235	前导布器滑块弹簧片	Lap Former Slide Block Spring	1
10	A1223	螺钉	Screw (3/32-56x2.8)	1
11	A1236	前导布器导轨(左)	Lap Former Guide Plate (Left)	1
12	A1237	前导布器导轨(右)	Lap Former Guide Plate (Right)	1
13	A0218	螺钉	Screw (1/8-44x6.5)	1
14	A1239	下巴盖板	Sewing Cylinder Cover (Upper)	1
15	A0219	防尘盖(上)	Dust Defender (Upper)-	1
16	A0220	螺钉	Screw (3/32-56x2.1)	1

主零件型号区分CLASS LIST OF MAIN SPARE PARTS

Models	Main Parts					
						
	压脚组件	压脚	压脚弹簧片(左)	压脚弹簧片(右)	护针(后)	护针(前)
01MR	A0614	A0615	A0636	A0668	A1010	A0645
01MS	A0666	A0667	"	"	"	"
12MR	A1201	A1202	B12124	B12125	"	"
12MS	A1257	A1256	"	"	"	"
12HR	B1901	B1902	B1924	B1925	"	"
12HS	B0012H	B1902	"	"	"	"
01HR	B2205	B2202	A0636	A0668	"	"
01HS	B2305	B2334	"	"	"	"

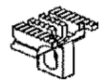
Models	Main Parts					
						
	喂针线托架	喂针线过线勾	导布板	针板舌头	差动齿	主送齿
01MR	A0625	A0622		A0545	A1007	A1008
DIMS	A0669	"		A0561	"	"
12MR	A0625	"	A1222	A0545	"	A1241
12MS	A0669	"	"	A0561	"	"
12HR	A0625	"	B1922	A0545	"	"
12HS	A0669	"		A0561	"	"
01HR	A0625	"		A0545	"	A1008
01HS	A0669	"		A0561	"	"

						
Stitch Plate	Lap Former	Needle Clamp	Yielding Section	Upper Knife	Lower Knife	Lower Knife Clamp
针板	铺布器	针古	压脚辅助座	上刀片	下刀片	下刀夹板
A0544		A0540	A0634	A0742	A0630	A1218
A0560		A0559	“	“	“	“
A1242	A1231	A0540	A1221	“	“	“
A1255	“	A0559	“	“	IT	“
A1242	B1933	A0540	“	B2109	B1917	“
A1255	“	A0559	“	“	“	“
A1242		A0540	A0634	A0742	A0630	“
A1255		A0559	“	“	“	“

杰克缝纫机
全球销量遥遥领先
Leading in global sales

400-8876-858
www.chinajack.com



JACK SEWING MACHINE CO.,LTD.

2019年11月份 Edition:November.2019

杰克缝纫机股份有限公司

中国浙江省台州市椒江区三甲东海大道东段1008号

电话：0086-576-88177788 88177789

传真：0086-576-88177758

产品标准代号：Q/TK 007-2017

资料如有更改，恕不另行通知，以实样为准

JACK SEWING MACHINE CO.LTD.

NO.1008, DONGHAI AVENUE EAST, JIAOJIANG DISTRICT,TAIZHOU CITY, ZHEJIANG

TEL: 0086-576-88177782 88177767 E-mail: sales@chinajack.com

Standard code of the products:Q/TK 007-2017

You will be not informed if the file has been revised.Please set sample as standard.